

Anritsu envision : ensure

Signal Analyzer MS2690A/MS2691A/MS2692A

Vector Signal Generator Option MS2690A-020/MS2691A-020/MS2692A-020

Signal Analyzer MS2840A

Vector Signal Generator Option MS2840A-020/MS2840A-021

Signal Analyzer MS2830A

Vector Signal Generator Option MS2830A-020/MS2830A-021

MX269xxxA series Software

Waveform Pattern

MX2690xxA

IQproducer

MX2699xxA



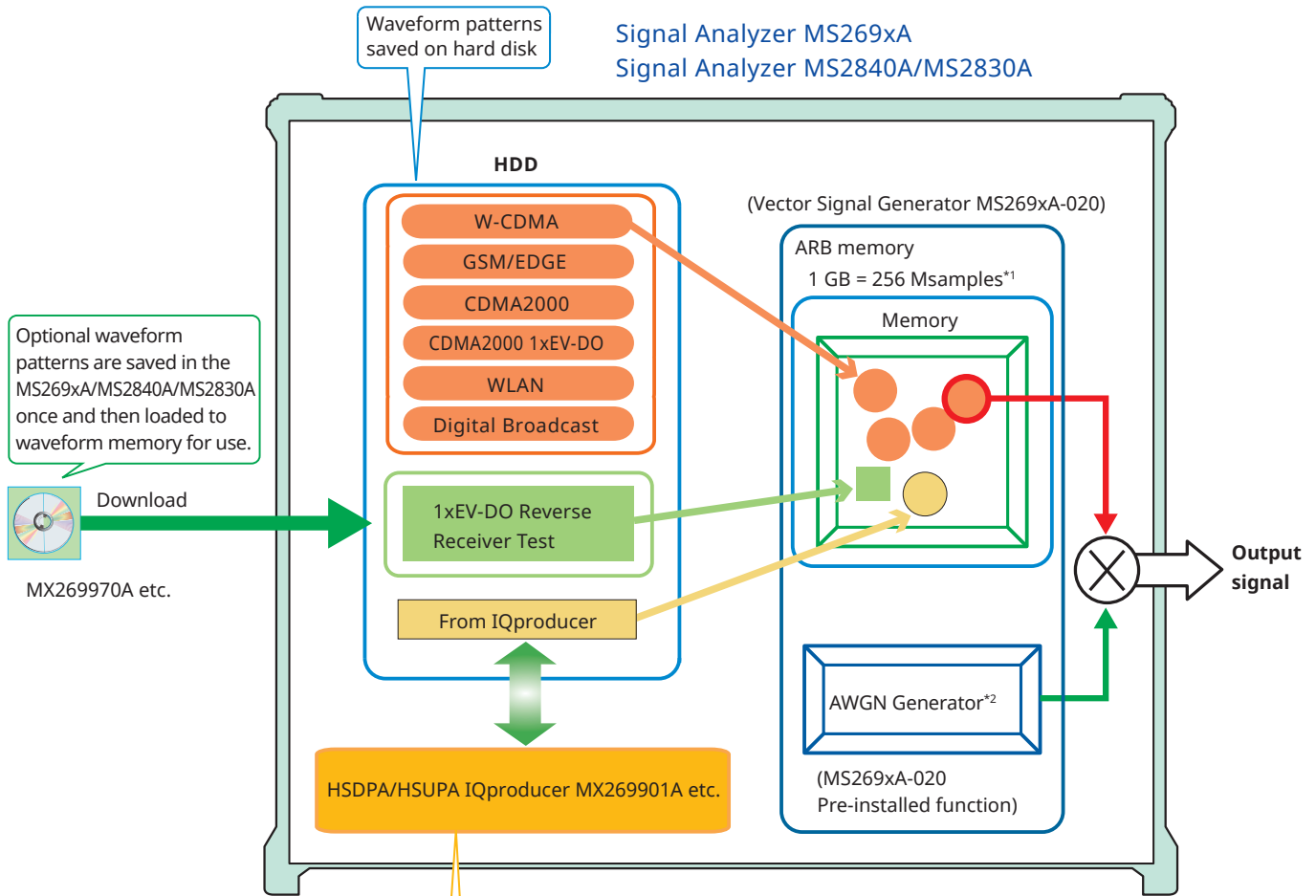

IQproducer is PC application software used for generating waveform pattern files for the Vector Signal Generator Option by editing parameters for the modulation signals matching the target communication system. The generated waveform pattern files are saved in the MS269xA or MS2840A/MS2830A once and then loaded to the waveform memory for use.

*1: The MS2840A/MS2830A-020/021 arbitrary waveform memory is 256 MB (64 Msamples).
Expansion to 1 GB (256 Msamples) requires the separate MS2840A/MS2830A-027 ARB Memory Upgrade 256 MSa for Vector Signal Generator option.
*2: The MS2840A/MS2830A-020/021 requires the separate MS2840A/MS2830A-028 AWGN option.

IQproducer Operating Environment

OS	Windows 2000 Professional*1, Windows XP, Windows Vista*2, Windows 7 Enterprise (32-bit)*2, Windows 7 Professional (32-bit/64-bit)*2
CPU	Pentium III 1 GHz equivalent or faster
Memory	512 MB or more
Hard Disk Space	5 GB or more free space on the drive where this software is to be installed. The free hard disk space necessary to create waveform pattern varies depending on the waveform pattern size. The free disk space of 27 GB or greater is required to create four maximum (512 Msamples) waveform patterns.

*1: Does not support IQproducer Version 13.00 and later
*2: Supports IQproducer Version 12.00 and later

Windows® is a registered trademark of Microsoft Corporation in the USA and other countries.
Pentium® is registered trademarks of Intel Corporation or its subsidiaries in the USA and other countries.

Additive White Gaussian Noise (AWGN) Generator

MS269xA-020: Pre-installed function
 MS2840A/MS2830A-020/021: Requires the separate MS2840A/MS2830A-028 AWGN option

MS269xA

MS2840A

MS2830A

The noise signal of the AWGN generator can be added to the wanted signal of the arbitrary waveform memory.

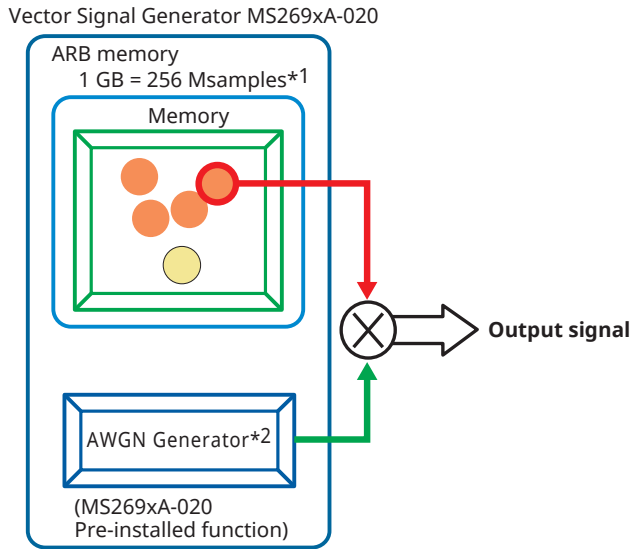

- *1: The MS2840A/MS2830A-020/021 arbitrary waveform memory is 256 MB (64 Msamples). Expansion to 1 GB (256 Msamples) requires the separate Vector Signal Generator ARB Memory Upgrade 256 MSa MS2840A/MS2830A-027.
- *2: The MS2840A/MS2830A-020/021 requires the separate AWGN MS2840A/MS2830A-028.

Parameter Setting Range

Display	Function
AWGN On/Off	On, Off
C/N Set Signal	Carrier, Noise, Constant Carrier: Noise Power is a fixed value. Carrier Power is set. Noise: Carrier Power is a fixed value. Noise Power is set. Constant: Amplitude is a fixed value. Level ratio of C/N is set.
Carrier Power	The output level of Carrier Power is set.
C/N Ratio	Level ratio of Carrier Power and converted Noise Power is set. $-40 \text{ dB} \leq \text{C/N Ratio} \leq +40 \text{ dB}$

Condition of Parameter Setting Range

The parameter of the AWGN generator has the following restriction.

- $-40 \text{ dB} \leq \text{C/N Ratio} \leq +40 \text{ dB}$
- Amplitude $\leq 0 \text{ dBm}$

AWGN Supports Dynamic Range Testing

The 3GPP specifications for testing receiver dynamic range require a AWGN + W-CDMA modulation signal.

The Internal AWGN generator can be used to produce the AWGN signal.

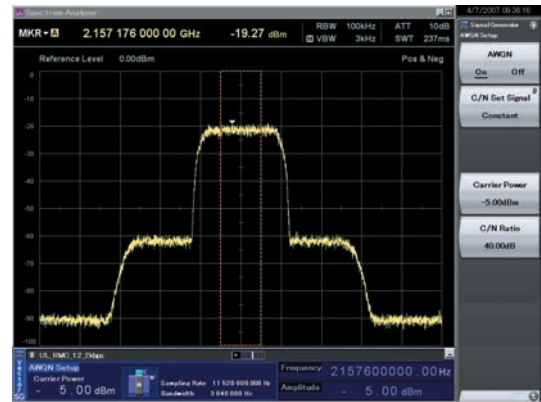
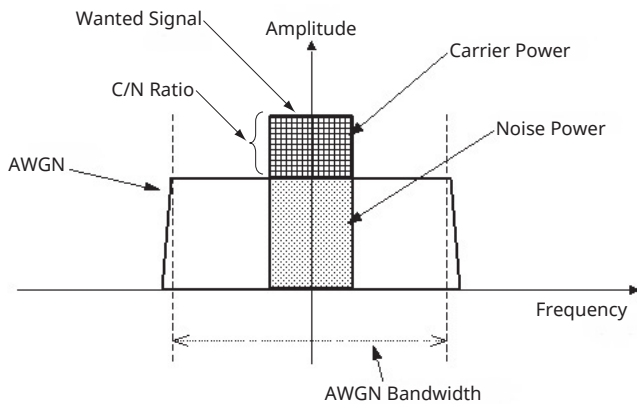

Wanted Signal + AWGN Output Waveform

- Carrier Power: Output level of wanted signal
- Noise Power: Output level value of AWGN converted by bandwidth of wanted signal (It is not displayed on the screen.)
- C/N Ratio: Level ratio of Carrier Power and Noise Power.
- Amplitude: Combination of wanted signal level and AWGN level.

AWGN Bandwidth

The bandwidth of AWGN is the same as the sampling clock of the wanted signal.

Sample:

When the condition of the wanted signal is the following

- W-CDMA
- BW = 3.84 MHz
- Over Sampling Rate = 4

Calculation:

$$\text{AWGN Bandwidth} = 3.84 \text{ MHz} \times 4 = 15.36 \text{ MHz}$$

W-CDMA Waveform Patterns

Standard

MS269xA

MS2840A

MS2830A

The following W-CDMA waveform patterns are installed on the internal hard disk when MS269xA-020 or MS2840A/MS2830A-020/021, Vector Signal Generator Option is installed.

Details for each pattern file is given on the next page.

For Evaluating Base Station Transmitter Devices (TS 25.141 Test Model 1 to 6)

- TestModel_1_4DPCH
- TestModel_1_8DPCH
- TestModel_1_16DPCH
- TestModel_1_32DPCH
- TestModel_1_64DPCH
- TestModel_1_64x2_10M
- TestModel_1_64x2_15M
- TestModel_1_64DPCHx2
- TestModel_1_64DPCHx3
- TestModel_1_64DPCHx4
- TestModel_2
- TestModel_3_4DPCH
- TestModel_3_8DPCH
- TestModel_3_16DPCH
- TestModel_3_32DPCH
- TestModel_4
- TestModel_4_CPICH
- TestModel_5_2HSPDSCH
- TestModel_5_4HSPDSCH
- TestModel_5_8HSPDSCH
- TestModel_6_4HSPDSCH
- TestModel_6_8HSPDSCH

For Testing BS Receiver Performance (TS 25.101/ 25.104 UL RMC 12.2 to 384 kbps)

- UL_RMC_12_2kbps
- UL_RMC_64kbps
- UL_RMC_144kbps
- UL_RMC_384kbps
- UL_AMR_TFCS1
- UL_AMR_TFCS2
- UL_AMR_TFCS3
- UL_ISDN
- UL_64kbps_Packet
- UL_Interfere

For Evaluating UE Transmitter Devices (TS 25.101 A2.1)

- UL_RMC_12_2kbps_TX

For Testing UE Receiver Performance (TS 25.101 DL RMC 12.2 to 384 kbps)

- DL_RMC_12_2kbps_RX
- DL_RMC_12_2kbps
- DL_RMC_12_2kbps_MIL
- DL_RMC_64kbps
- DL_RMC_144kbps
- DL_RMC_384kbps
- DL_AMR_TFCS1
- DL_AMR_TFCS2
- DL_AMR_TFCS3
- DL_ISDN
- DL_384kbps_Packet
- DL_Interfere

Uplink and downlink W-CDMA modulation signals conforming to the 3GPP (FDD) standards can be output simply by selecting the waveform from the patterns on the internal hard disk without setting any complex 3GPP-compliant parameters.

W-CDMA Waveform Patterns

Standard

MS269xA

MS2840A

MS2830A

W-CDMA Waveform Patterns List

Waveform Patterns	Uplink/ Downlink	Channel	3GPP	Evaluation	
UL_RMC_12_2kbps*1	Uplink	DPCCH, DPDCH	TS 25.141 A.2	BS Rx Test	
UL_RMC_64kbps*1		DPCCH, DPDCH	TS 25.141 A.3		
UL_RMC_144kbps*1		DPCCH, DPDCH	TS 25.141 A.4		
UL_RMC_384kbps*1		DPCCH, DPDCH	TS 25.141 A.5		
UL_AMR_TFCS1*1		DPCCH, DPDCH	TS 25.944 4.1.2		
UL_AMR_TFCS2*1		DPCCH, DPDCH			
UL_AMR_TFCS3*1		DPCCH, DPDCH			
UL_ISDN*1, *2		DPCCH, DPDCH			
UL_64kbps_Packet*1		DPCCH, DPDCH			
UL_Interfere		DPCCH, DPDCH	TS 25.141 I		
UL_RMC_12_2kbps_TX*1		DPCCH, DPDCH	TS 25.101 A.2.1		UE Tx Device Test
DL_RMC_12_2kbps_RX*1	Downlink	P-CPICH, SCH, PICH, DPCH	TS 25.101 A.3.1	UE Rx Test	
DL_RMC_12_2kbps_MIL*1		P-CPICH, SCH, PICH, DPCH, OCNS	TS 25.101 C.3.1		
DL_RMC_12_2kbps*1		P-CPICH, SCH, PICH, DPCH, OCNS	TS 25.101 A.3.1		
DL_RMC_64kbps*1		P-CPICH, SCH, PICH, DPCH, OCNS	TS 25.101 C.3.2		
DL_RMC_144kbps*1		P-CPICH, SCH, PICH, DPCH, OCNS	TS 25.101 A.3.3/C3.2		
DL_RMC_384kbps*1		P-CPICH, SCH, PICH, DPCH, OCNS	TS 25.101 A.3.4/C3.2		
DL_AMR_TFCS1*1		P-CPICH, SCH, PICH, DPCH, OCNS	TS 25.944 4.1.1.3 TS 25.101 C.3.2		
DL_AMR_TFCS2*1		P-CPICH, SCH, PICH, DPCH, OCNS			
DL_AMR_TFCS3*1		P-CPICH, SCH, PICH, DPCH, OCNS			
DL_ISDN*1		P-CPICH, SCH, PICH, DPCH, OCNS			
DL_384kbps_Packet*1		P-CPICH, SCH, PICH, DPCH, OCNS			
DL_Interfere		P-CPICH, P-CCPCH, SCH, PICH, OCNS	TS 25.101 C.4		
DL_CPICH		P-CPICH	-		
TestModel_1_4DPCH		P-CPICH, P-CCPCH, SCH, PICH, S-CCPCH, 4DPCH	TS 25.141 6.1.1		BS Tx Device Test
TestModel_1_8DPCH		P-CPICH, P-CCPCH, SCH, PICH, S-CCPCH, 8DPCH			
TestModel_1_16DPCH		P-CPICH, P-CCPCH, SCH, PICH, S-CCPCH, 16DPCH			
TestModel_1_32DPCH		P-CPICH, P-CCPCH, SCH, PICH, S-CCPCH, 32DPCH			
TestModel_1_64DPCH		P-CPICH, P-CCPCH, SCH, PICH, S-CCPCH, 64DPCH			
TestModel_1_64DPCH*2*2		P-CPICH, P-CCPCH, SCH, PICH, S-CCPCH, 64DPCH			
TestModel_1_64DPCH*3*2		P-CPICH, P-CCPCH, SCH, PICH, S-CCPCH, 64DPCH			
TestModel_1_64DPCH*4*2		P-CPICH, P-CCPCH, SCH, PICH, S-CCPCH, 64DPCH			
TestModel_1_64*2_10M*2, *3	P-CPICH, P-CCPCH, SCH, PICH, S-CCPCH, 64DPCH				
TestModel_1_64*2_15M*2, *3	P-CPICH, P-CCPCH, SCH, PICH, S-CCPCH, 64DPCH				
TestModel_2	P-CPICH, P-CCPCH, SCH, PICH, S-CCPCH, 3DPCH				
TestModel_3_4DPCH	P-CPICH, P-CCPCH, SCH, PICH, S-CCPCH, 4DPCH				
TestModel_3_8DPCH	P-CPICH, P-CCPCH, SCH, PICH, S-CCPCH, 8DPCH				
TestModel_3_16DPCH	P-CPICH, P-CCPCH, SCH, PICH, S-CCPCH, 16DPCH				
TestModel_3_32DPCH	P-CPICH, P-CCPCH, SCH, PICH, S-CCPCH, 32DPCH				
TestModel_4	P-CCPCH, SCH				
TestModel_4_CPICH	P-CPICH, P-CCPCH, SCH				
TestModel_5_4DPCH	P-CPICH, P-CCPCH, SCH, PICH, S-CCPCH, 4DPCH, HS-SCCH, 4HS-PDSCH				
TestModel_5_2HSPDSCH	P-CPICH, P-CCPCH, SCH, PICH, S-CCPCH, 6DPCH, HS-SCCH, 2HS-PDSCH				
TestModel_5_4HSPDSCH	P-CPICH, P-CCPCH, SCH, PICH, S-CCPCH, 14DPCH, HS-SCCH, 4HS-PDSCH				
TestModel_5_8HSPDSCH	P-CPICH, P-CCPCH, SCH, PICH, S-CCPCH, 30DPCH, HS-SCCH, 8HS-PDSCH				
TestModel_6_4HSPDSCH	P-CPICH, P-CCPCH, SCH, PICH, S-CCPCH, 4DPCH, HS-SCCH, 4HS-PDSCH				
TestModel_6_8HSPDSCH	P-CPICH, P-CCPCH, SCH, PICH, S-CCPCH, 30DPCH, HS-SCCH, 8HS-PDSCH				

*1: For MS2840A/MS2830A: ARB Memory Upgrade 256 Msample option must be installed to use this waveform pattern.

*2: *2, *3, and *4 indicate multi-carrier 2, 3, and 4, respectively.

*3: 10M and 15M indicate the multi-carrier inter frequency gap.

W-CDMA Waveform Patterns

Standard

MS269xA

MS2840A

MS2830A

Adjacent Channel Leakage Power Ratio (ACPR)

The ACPR is an important function for testing device distortion and receiver interference.

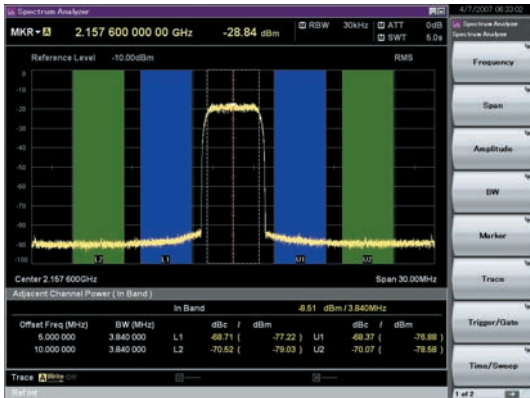

W-CDMA ACPR (Test Model 1, 64 DPCH, 1 Carrier) Waveform Pattern [Test_Model_1_64DPCH]



W-CDMA ACPR (Test Model 1, 64 DPCH, 4 Carrier) Waveform Pattern [Test_Model_1_64DPCH x 4]

Complementary Cumulative Distribution Function (CCDF)



CCDF (Test Model 1, 64 DPCH, 1 Carrier) Waveform Pattern [Test_Model_1_64DPCH]



CCDF (Test Model 1, 64 DPCH, 4 Carrier) Waveform Pattern [Test_Model_1_64DPCH x 4]

AWGN Supports Dynamic Range Testing

The 3GPP specifications for testing receiver dynamic range require a AWGN + W-CDMA modulation signal.

The Internal AWGN generator can be used to produce the AWGN signal.

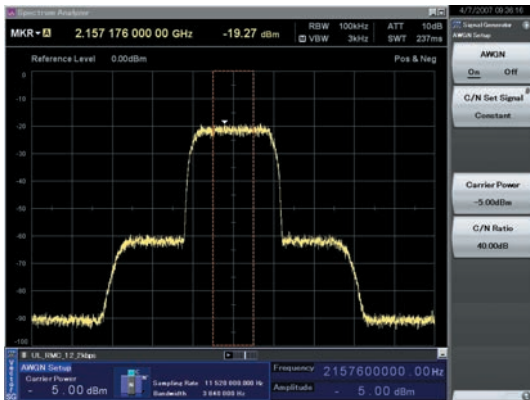

Wanted Signal + AWGN Output Waveform

CDMA2000 1xEV-DO Waveform Patterns

Standard

MS269xA

MS2840A

MS2830A

The CDMA2000 1xEV-DO waveform patterns listed opposite are stored on the MS269xA or MS2840A/MS2830A internal hard disk. The 3GPP2 signals specified for testing receivers and transmitters of CDMA2000 1xEV-DO access networks (base station) and access terminal (AT) are output by selecting one of the 13 forward and 10 reverse data rate patterns.

Access Terminal (AT) Receiver Test

CDMA2000 1xEV-DO forward

Baseband filter: IS-95SPEC +EQ

Data: PN15fix* (excluding FWD-Idle)

FWD_38_4kbps_16slot
FWD_76_8kbps_8slot
FWD_153_6kbps_4slot
FWD_307_2kbps_2slot
FWD_614_4kbps_1slot
FWD_307_2kbps_4slot
FWD_614_4kbps_2slot
FWD_1228_8kbps_1slot
FWD_921_6kbps_2slot
FWD_1843_2kbps_1slot
FWD_1228_8kbps_2slot
FWD_2457_6kbps_1slot
FWD_Idle

Access Network (AN) Receiver Test

CDMA2000 1xEV-DO Reverse

Baseband filter: IS-95SPEC

Data: PN9fix*

RVS_9_6kbps_RX
RVS_19_2kbps_RX
RVS_38_4kbps_RX
RVS_76_8kbps_RX
RVS_153_6kbps_RX
RVS_9_6kbps_TX
RVS_19_2kbps_TX
RVS_38_4kbps_TX
RVS_76_8kbps_RT
RVS_153_6kbps_RT

*: This displays the delimited PN sequence for each packet. Therefore, the PN sequence is discontinuous between the end data of one packet and the header data of the next packet.

CDMA2000 Waveform Patterns

Standard

MS269xA

MS2840A

MS2830A

The CDMA2000 waveform patterns listed in the table below are stored on the MS269xA or MS2840A/MS2830A internal hard disk. The 3GPP2 C.S0002-0-2-specified CDMA2000 modulation signals are output by selecting one of these CDMA2000 waveform patterns.

Reverse channel signals are output by channel coding (convolutional coding, etc.) 4-frame length PN9 fix*¹ data, which is useful for measuring the Frame Error Rate (FER)*² of base stations and evaluating devices.

*1: Since the data length is not an integer multiple of the PN sequence length (511 bits for PN9), the PN sequence becomes discontinuous at the end.

*2: This is the case when the timing signal and 1.2288 Mcps × 11 clock signal (or 5- or 10- MHz reference clock) can be input from the test target base station to the MS269xA or MS2840A/MS2830A in order to synchronize the frame start point and chip clock.

Waveform Patterns	System	Frame Coding	Symbol Data
RVS_RC1_FCH	CDMA2000 1XRTT RC1 Reverse	Coded	FCH 9.6 kbps
RVS_RC2_FCH	CDMA2000 1XRTT RC2 Reverse	Coded	FCH 14.4 kbps
RVS_RC3_FCH	CDMA2000 1XRTT RC3 Reverse	Coded	PICH, FCH 9.6 kbps
RVS_RC3_FCH_SCH	CDMA2000 1XRTT RC3 Reverse	Coded	PICH, FCH 9.6 kbps, SCH 9.6 kbps
RVS_RC3_DCCH	CDMA2000 1XRTT RC3 Reverse	Coded	PICH, DCCH 9.6 kbps
RVS_RC4_FCH	CDMA2000 1XRTT RC4 Reverse	Coded	PICH, FCH 14.4 kbps
FWD_RC1-2_9channel	CDMA2000 1XRTT RC1, RC2 Forward	Spreading only	PICH, SyncCH, PagingCH, FCH 19.2 kbps × 6
FWD_RC3-5_9channel	CDMA2000 1XRTT RC3, RC4, RC5 Forward	Spreading only	PICH, SyncCH, PagingCH, FCH 38.4 kbps × 6

Waveform Patterns		Walsh Code	Code Power	Data Rate	Data
RVS_RC1_FCH	R-FCH			9.6 kbps	PN9fix*
RVS_RC2_FCH	R-FCH			14.4 kbps	PN9fix*
RVS_RC3_FCH	R-PICH	0	-5.278 dB	N/A	All"0"
	R-FCH	4	-1.528 dB	9.6 kbps	PN9fix*
RVS_RC3_FCH_SCH	R-PICH	0	-7.5912 dB	N/A	All"0"
	R-FCH	4	-3.8412 dB	9.6 kbps	PN9fix*
	R-SCH	2	-3.8412 dB	9.6 kbps	PN9fix*
RVS_RC3_DCCH	R-PICH	0	-5.278 dB	N/A	All"0"
	R-DCCH	8	-1.528 dB	9.6 kbps	PN9fix*
RVS_RC4_FCH	R-PICH	0	-5.278 dB	N/A	All"0"
	R-FCH	4	-1.528 dB	14.4 kbps	PN9fix*
Waveform Patterns		Walsh Code	Code Power	Symbol Rate	Symbol Data
FWD_RC1-2_9channel	F-PICH	0	-7.0 dB	N/A	All"0"
	F-SyncCH	32	-13.3 dB	4.8 kbps	PN9fix*
	PagingCH	1	-7.3 dB	19.2 kbps	PN9fix*
	F-FCH × 6	8-13	-10.3 dB	19.2 kbps	PN9fix*
FWD_RC3-5_9channel	F-PICH	0	-7.0 dB	N/A	All"0"
	F-SyncCH	32	-13.3 dB	4.8 kbps	PN9fix*
	PagingCH	1	-7.3 dB	19.2 kbps	PN9fix*
	F-FCH × 6	8-13	-10.3 dB	38.4 kbps	PN9fix*

R-PICH (Reverse Pilot Channel)

R-FCH (Reverse Fundamental Channel)

R-SCH (Reverse Supplemental Channel)

R-DCCH (Reverse Dedicated Control Channel)

F-PICH (Forward Pilot Channel)

F-SyncCH (Forward Sync Channel)

PagingCH (Paging Channel)

F-FCH (Forward Fundamental Channel)

GSM/EDGE Waveform Patterns

Standard

MS269xA

MS2840A

MS2830A

The GSM/EDGE waveform patterns listed in the table below are installed on the internal hard disk when the MS269xA-020 or MS2840A/MS2830A-020/021, Vector Signal Generator Option is installed. Details for the pattern files are given below.

Signals for testing receivers and for evaluating devices in a GSM/EDGE system are output by selecting one of these GSM/EDGE waveform patterns.

GMSK_PN9, 8PSK_PN9

PN9 data which doesn't have slot format is inserted.

GMSK_TN0, 8PSK_TN0

PN9 data is inserted into the entire area of the slots, except the guard. The PN9 data in each slot is continuous.

NB_GMSK, NB_ALL_GMSK, NB_8PSK, NB_ALL_8PSK

PN9 data is inserted into the normal burst encrypted bit area. The PN9 data in the slots is continuous.

TCH_FS

Supports Speech channel at full rate (TCH/FS) specified in Section 3.1 of 3GPP TS 05.03

CS-1_1 (4)_SLOT (_4SLOT)

Supports packet data block type 1 (CS-4) and 4 (CS-1) specified in Section 5.1 of 3GPP TS 05.03

DL (UL)_MCS-1 (5, 9)_1SLOT (_4SLOT)

Supports packet data block types 5 (MCS-1), 9 (MCS-5), and 13 (MCS-9) specified in Section 5.1 of 3GPP TS 05.03

Waveform Patterns	Uplink/Downlink	Data	Output Slot	Communications	
GMSK_PN9	Uplink/Downlink	PN9*1	-	-	
8PSK_PN9	Uplink/Downlink		-	-	
GMSK_TN0	Uplink/Downlink	PN9*2	TN0	-	
8PSK_TN0	Uplink/Downlink		TN0	-	
NB_GMSK	Uplink/Downlink	PN9*3	TN0	GSM	
NB_ALL_GMSK	Uplink/Downlink		All slots		
NB_8PSK	Uplink/Downlink		TN0		
NB_ALL_8PSK	Uplink/Downlink		All slots		
TCH_FS	Uplink/Downlink	PN9*4	TN0	GPRS	
CS-1_1SLOT	Uplink/Downlink		TN0		
CS-4_1SLOT	Uplink/Downlink		TN0		
DL_MCS-1_1SLOT	Downlink		TN0		
UL_MCS-1_1SLOT	Uplink		TN0		
DL_MCS-5_1SLOT	Downlink		TN0		EDGE
UL_MCS-5_1SLOT	Uplink		TN0		
DL_MCS-9_1SLOT	Downlink		TN0		
UL_MCS-9_1SLOT	Uplink		TN0		
DL_MCS-9_4SLOT*5	Downlink		TN0, 1, 2, 3		
UL_MCS-9_4SLOT*5	Uplink	TN0, 1, 2, 3			

*1: PN9 data is inserted into the entire area that does not have the slot format.

*2: PN9 data is inserted into the entire area of the slots, except the guard.

*3: PN9 data is inserted into the normal burst encrypted bit area.

*4: The bit string channel-coded for PN9 data is inserted into the normal burst encrypted bit area.

*5: For MS2840A/MS2830A: ARB Memory Upgrade 256 MSa option must be installed to use this waveform pattern.

Digital Broadcast Waveform Patterns

Standard

MS269xA

MS2840A

MS2830A

The BS/CS/CATV/ISDB-T waveform patterns listed in the table below are stored on the MS269xA or MS2840A/MS2830A internal hard disk and signals for testing devices are output by selecting one of these waveform patterns.

There is also a pattern for evaluating ISDB-T video and audio as well as for simple BER measurements.

Waveform Patterns	Outline		Parameter
BS_1ch	Physical layer waveform pattern of digital BS broadcast. For device evaluation.	1 channel PN23fix*1 Modulation only	Roll-off factor: 0.35 Nyquist Bandwidth: 28.86 MHz Modulation: QPSK
CS_1ch	Physical layer waveform pattern of digital CS broadcast. For device evaluation.		Roll-off factor: 0.35 Nyquist Bandwidth: 21.096 MHz Modulation: QPSK
CATV_AnnexC_1ch	Physical layer waveform pattern for CATV (ITU-T J83 Annex C). For device evaluation.		Roll-off factor: 0.13 Nyquist Bandwidth: 5.274 MHz Modulation: 64QAM
ISDBT_1layer_1ch	Physical layer waveform pattern for ISDB-T. For device evaluation.	1 channel PN23fix*1 Pilot Signal With TMCC	Mode: 3, GI: 1/8 A-Layer: 13seg, 64QAM
ISDBT_2layer_1ch			Mode: 3, GI: 1/8 A-Layer: 1seg, QPSK B-Layer: 12seg, 64QAM
ISDBT_2layer_Coded	Waveform pattern for ISDB-T partial reception. For simple BER measurement. 4-frame waveform length.	1 channel For simple BER	Mode: 3, GI: 1/8 A-Layer: 1seg, QPSK, CR = 2/3, TI = 2 B-Layer: 12seg, 64QAM, CR = 7/8, TI = 2
ISDBT_QPSK_1_2			Mode: 3, GI: 1/8 A-Layer: 1seg, QPSK, CR = 1/2, TI = 0 B-Layer: 12seg, 64QAM, CR = 7/8, TI = 1
ISDBT_QPSK_2_3			Mode: 3, GI: 1/8 A-Layer: 1seg, QPSK, CR = 2/3, TI = 0 B-Layer: 12seg, 64QAM, CR = 7/8, TI = 1
ISDBT_16QAM_1_2			Mode: 3, GI: 1/8 A-Layer: 1seg, 16QAM, CR = 1/2, TI = 0 B-Layer: 12seg, 64QAM, CR = 7/8, TI = 1
ISDBT_QPSK_2_3_TI4			Mode: 3, GI: 1/8 A-Layer: 1seg, QPSK, CR = 2/3, TI = 4 B-Layer: 12seg, 64QAM, CR = 3/4, TI = 2
ISDBTsb_QPSK_1_2	Waveform pattern for ISDB-Tsb partial reception*2. For simple BER measurement. 4-frame waveform length.	1 channel For simple BER	Mode: 3, GI: 1/8 A/B-Layer: QPSK, CR = 1/2, TI = 0 Seg#1 to #5: 8-segment concatenation transmission in 1-segment format Seg#6 to #8: 8-segment concatenation transmission in 3-segment format
ISDBTsb_QPSK_2_3			Mode: 3, GI: 1/8 A/B-Layer: QPSK, CR = 2/3, TI = 0 Seg#1 to #5: 8-segment concatenation transmission in 1-segment format Seg#6 to #8: 8-segment concatenation transmission in 3-segment format
ISDBTsb_16QAM_1_2			Mode: 3, GI: 1/8 A/B-Layer: 16QAM, CR = 1/2, TI = 0 Seg#1 to #5: 8-segment concatenation transmission in 1-segment format Seg#6 to #8: 8-segment concatenation transmission in 3-segment format

*1: The PN sequence is discontinuous at the waveform pattern connection.

This cannot be used to measure BER (PN23) although it can be used for simple BER measurement.

*2: It is not guaranteed that any receiver can receive a waveform with this length.

WLAN Waveform Patterns

Standard

MS269xA

MS2840A

MS2830A

The WLAN (IEEE 802.11a/b/g) waveform patterns listed in the table below are stored on the MS269xA or MS2840A/MS2830A internal hard disk.

Signals for testing the receiver and transmitter of a terminal or module can be output by selecting one of these patterns.

The waveform patterns shown below are the signals for one packet. When a waveform pattern is selected, the signal is output in an endless loop.

IEEE 802.11a/IEEE 802.11g (ERP-OFDM) Waveform Patterns List

Waveform Patterns	Data Rate (Mbps)	Modulation	Coding Rate	Coding Bits per Sub-carrier	Coding Bits per OFDM Symbol	Data Bits per OFDM Symbol
11a_OFDM_6Mbps	6	BPSK	1/2	1	48	24
11a_OFDM_9Mbps	9	BPSK	3/4	1	48	36
11a_OFDM_9Mbps_PN9*1	9	BPSK	3/4	1	48	36
11a_OFDM_12Mbps	12	QPSK	1/2	2	96	48
11a_OFDM_18Mbps	18	QPSK	3/4	2	96	72
11a_OFDM_18Mbps_PN9*1	18	QPSK	3/4	2	96	72
11a_OFDM_24Mbps	24	16-QAM	1/2	4	192	96
11a_OFDM_36Mbps	36	16-QAM	3/4	4	192	144
11a_OFDM_36Mbps_PN9*1	36	16-QAM	3/4	4	192	144
11a_OFDM_48Mbps	48	64-QAM	2/3	6	288	192
11a_OFDM_54Mbps	54	64-QAM	3/4	6	288	216
11a_OFDM_54Mbps_PN9*1	54	64-QAM	3/4	6	288	216
11a_OFDM_54Mbps_ACP*2	54	64-QAM	3/4	6	288	216

*1: Continuous PN9 data between PSDUs

*2: Improved ACPR

IEEE 802.11b Waveform Patterns List

Waveform Patterns	Spreading, Coding	Modulation
11b_DSSS_1Mbps	DSSS, 11 chip Barker Code	DBPSK
11b_DSSS_2Mbps	DSSS, 11 chip Barker Code	DQPSK
11b_DSSS_2Mbps_PN9*1, *2	DSSS, 11 chip Barker Code	DQPSK
11b_CCK_5_5Mbps	CCK	DQPSK
11b_CCK_11Mbps	CCK	DQPSK
11b_CCK_11Mbps_PN9*2	CCK	DQPSK
11b_CCK_11Mbps_ACP*3	CCK	DQPSK

*1: For MS2840A/MS2830A: ARB Memory Upgrade 256 MSa option must be installed to use this waveform pattern.

*2: Continuous PN9 data between PSDUs

*3: Improved ACPR

IEEE 802.11g (DSSS-OFDM) Waveform Patterns List

Waveform Patterns	Data Rate (Mbps)	Modulation	Coding Rate	Coding Bits per Sub-carrier	Coding Bits per OFDM Symbol	Data Bits per OFDM Symbol
11g_DSSS_OFDM_6Mbps	6	BPSK	1/2	1	48	24
11g_DSSS_OFDM_9Mbps	9	BPSK	3/4	1	48	36
11g_DSSS_OFDM_12Mbps	12	QPSK	1/2	2	96	48
11g_DSSS_OFDM_18Mbps	18	QPSK	3/4	2	96	72
11g_DSSS_OFDM_24Mbps	24	16-QAM	1/2	4	192	96
11g_DSSS_OFDM_36Mbps	36	16-QAM	3/4	4	192	144
11g_DSSS_OFDM_48Mbps	48	64-QAM	2/3	6	288	192
11g_DSSS_OFDM_54Mbps	54	64-QAM	3/4	6	288	216

Bluetooth Waveform Patterns

Standard

MS269xA

MS2840A

MS2830A

The *Bluetooth* waveform patterns listed in the table below are stored on the MS269xA or MS2840A/MS2830A internal hard disk. Selecting one of these waveform patterns outputs the best signal for the evaluation.

POLL:

This is used for operation checks and PER measurement of mobile terminals with *Bluetooth*.

No Packet Format (PN9, PN15):

This is used for BER measurement of mobile terminals and modules with *Bluetooth*.

DH1, DH3, DH5:

This is used in combination with an external demodulator for loopback tests (no FEC) of mobile terminals and modules with *Bluetooth*.

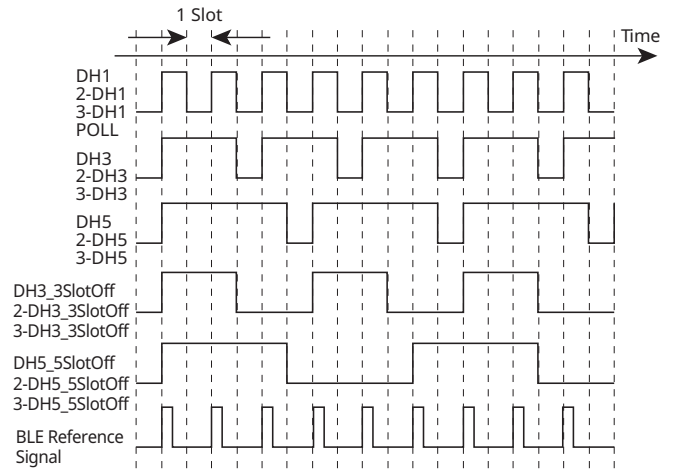

Waveform Timing Chart

Waveform Pattern Name	Data Rate (Mbits/s)	Modulation for Payload	Filter	Packet Type	Dirty, FM	File Size [MB]
DH1*1	1	GFSK*4	Gaussian*5	DH1	-	0.1
DH3*1	1	GFSK*4	Gaussian*5	DH3	-	0.2
DH5*1	1	GFSK*4	Gaussian*5	DH5	-	0.3
DH3_3SlotOff*1	1	GFSK*4	Gaussian*5	DH3	-	0.2
DH5_5SlotOff*1	1	GFSK*4	Gaussian*5	DH5	-	0.3
POLL	1	GFSK*4	Gaussian*5	POLL	-	0.1
2-DH1*1	2	$\pi/4$ -DQPSK	Root Nyquist*6	2-DH1	-	0.1
2-DH3*1	2	$\pi/4$ -DQPSK	Root Nyquist*6	2-DH3	-	0.2
2-DH5*1	2	$\pi/4$ -DQPSK	Root Nyquist*6	2-DH5	-	0.3
2-DH3_3SlotOff*1	2	$\pi/4$ -DQPSK	Root Nyquist*6	2-DH3	-	0.2
2-DH5_5SlotOff*1	2	$\pi/4$ -DQPSK	Root Nyquist*6	2-DH5	-	0.3
3-DH1*1	3	8-DPSK	Root Nyquist*6	3-DH1	-	0.1
3-DH3*1	3	8-DPSK	Root Nyquist*6	3-DH3	-	0.2
3-DH5*1	3	8-DPSK	Root Nyquist*6	3-DH5	-	0.3
3-DH3_3SlotOff*1	3	8-DPSK	Root Nyquist*6	3-DH3	-	0.2
3-DH5_5SlotOff*1	3	8-DPSK	Root Nyquist*6	3-DH5	-	0.3
GFSK-PN9*2	1	GFSK*4	Gaussian*5	No Packet Format	-	0.6
GFSK-PN15*3	1	GFSK*4	Gaussian*5	No Packet Format	-	37.5
PI_4_DQPSK-PN9*2	2	$\pi/4$ -DQPSK	Root Nyquist*6	No Packet Format	-	0.1
PI_4_DQPSK-PN15*3	2	$\pi/4$ -DQPSK	Root Nyquist*6	No Packet Format	-	6.0
8DPSK-PN9*2	3	8-DPSK	Root Nyquist*6	No Packet Format	-	0.2
8DPSK-PN15*3	3	8-DPSK	Root Nyquist*6	No Packet Format	-	12.0
DH1_dirty*1	1	GFSK*4	Gaussian*5	DH1	Dirty	9.2
DH3_dirty*1	1	GFSK*4	Gaussian*5	DH3	Dirty	9.2
DH5_dirty*1	1	GFSK*4	Gaussian*5	DH5	Dirty	9.2
2-DH1_dirty*1	2	$\pi/4$ -DQPSK	Root Nyquist*6	2-DH1	Dirty	3.5
2-DH3_dirty*1	2	$\pi/4$ -DQPSK	Root Nyquist*6	2-DH3	Dirty	10.3
2-DH5_dirty*1	2	$\pi/4$ -DQPSK	Root Nyquist*6	2-DH5	Dirty	17.2
3-DH1_dirty*1	3	8-DPSK	Root Nyquist*6	3-DH1	Dirty	3.5
3-DH3_dirty*1	3	8-DPSK	Root Nyquist*6	3-DH3	Dirty	10.3
3-DH5_dirty*1	3	8-DPSK	Root Nyquist*6	3-DH5	Dirty	17.2
DH1_Dirty_withFM*1	1	GFSK*4	Gaussian*5	DH1	Dirty, FM	9.2
DH3_Dirty_withFM*1	1	GFSK*4	Gaussian*5	DH3	Dirty, FM	9.2
DH5_Dirty_withFM*1	1	GFSK*4	Gaussian*5	DH5	Dirty, FM	9.2
2-DH1_Dirty_withFM*1	2	$\pi/4$ -DQPSK	Root Nyquist*6	2-DH1	Dirty, FM	3.5
2-DH3_Dirty_withFM*1	2	$\pi/4$ -DQPSK	Root Nyquist*6	2-DH3	Dirty, FM	10.3
2-DH5_Dirty_withFM*1	2	$\pi/4$ -DQPSK	Root Nyquist*6	2-DH5	Dirty, FM	17.2
3-DH1_Dirty_withFM*1	3	8-DPSK	Root Nyquist*6	3-DH1	Dirty, FM	3.5
3-DH3_Dirty_withFM*1	3	8-DPSK	Root Nyquist*6	3-DH3	Dirty, FM	10.3
3-DH5_Dirty_withFM*1	3	8-DPSK	Root Nyquist*6	3-DH5	Dirty, FM	17.2
BLE*1	1	GFSK*8	Gaussian*5	BLE Reference Signal	-	0.1
BLE_Dirty*1	1	GFSK*8	Gaussian*5	BLE Reference Signal	Dirty	28.7
BLE_Dirty_withFM*1	1	GFSK*8	Gaussian*5	BLE Reference Signal	Dirty, FM	28.7
BLE_CRC_corrupted*1, *7	1	GFSK*8	Gaussian*5	BLE Reference Signal	-	0.2
GFSK-PN15_BLE*3	1	GFSK*8	Gaussian*5	No Packet Format	-	6.0

*1: PN9 data is inserted into the payload body.

*2: PN9 data is inserted into all areas that do not have a packet format.

*3: PN15 data is inserted into all areas that do not have a packet format.

*4: Modulation index=0.32

*5: Bandwidth time (BT)=0.5

*6: Roll-off rate $\beta=0.4$

*7: Use in RF-PHY.TS/4.0.0 RCV-LE/CA/07/C (PER Report Integrity) with intentional CRC errors in every other packet is assumed.

*8: Modulation index = 0.5

* Since the recorded file size is rounded up to the nearest 0.1 MB, the true file size may be smaller.

Consider this when selecting the ARB memory upgrade option

GPS Waveform Patterns

Standard

MS269xA

MS2840A

MS2830A

The GPS waveform patterns listed in the table below are stored on the MS269xA or MS2840A/MS2830A internal hard disk. Selecting one of these waveform patterns outputs the modulation signal for the GPS receiver Rx test.

Waveform Patterns	Main Use	Outline
TLM	Sensitivity test	Consists of TLM, HOW, and default navigation data, formatted according to subframe configuration prescribed in Global Positioning System (GPS) Standard Positioning Service (SPS) Signal Specification
PARITY	Parity detection	Configured in word format prescribed in Global Positioning System Standard Positioning Service Signal Specification. One word consists of 24-bit PN9fix data and 6-bit parity bit data.
TLM_PARITY		Configured in word format prescribed in Global Positioning System Standard Positioning Service Signal Specification. One word consists of 24-bit random data and 6-bit parity bit data.
PN9	BER measurement	Consecutive PN9 data not configured in subframe format.

GLONASS Waveform Patterns

Standard

MS269xA

MS2840A

MS2830A

The GLONASS waveform patterns listed in the table below are stored on the MS269xA or MS2840A/MS2830A internal hard disk. Selecting one of these waveform patterns outputs the modulation signal for the GLONASS receiver Rx test.

Waveform Patterns	Main Use	Outline
15String_Message	Sensitivity test	Consists of String Structure prescribed in Global Navigation Satellite System (GLONASS) Interface Control Document.
15String_PN9	Check bit detection	
GLONASS_PN9	BER measurement	Consecutive PN9 data not configured in String and Frame format.

QZSS Waveform Patterns

Standard

MS269xA

MS2840A

MS2830A

The QZSS waveform patterns listed in the table below are stored on the MS269xA or MS2840A/MS2830A internal hard disk. Selecting one of these waveform patterns outputs the modulation signal for the QZSS receiver Rx test.

Waveform Patterns	Main Use	Outline
DefaultNavData	Sensitivity test	Consists of TLM, HOW, and default navigation data, formatted according to subframe configuration prescribed in Global Positioning System (GPS) Standard Positioning Service (SPS) Signal Specification.
ENC	Parity detection	Configured in word format prescribed in Global Positioning System Standard Positioning Service Signal Specification. One word consists of 24-bit PN9fix data and 6-bit parity bit data.
PARITY		Configured in word format prescribed in Global Positioning System Standard Positioning Service Signal Specification. One word consists of 24-bit random data and 6-bit parity bit data.
QZSS_PN9	BER measurement	Consecutive PN9 data not configured in subframe format

W-CDMA IQproducer is GUI-based, PC application software for generating waveform patterns used in W-CDMA Rx sensitivity measurement. Once created, the waveform pattern file is downloaded to the MS269xA or MS2830A hard drive. Using the MS269xA-020 or MS2830A-020/021, Vector Signal Generator Option functionality, the files are loaded, selected, and output as a modulated RF signal.

By changing the Scrambling Code Number and Channelization Code Number, waveform patterns can be created that support the evaluation of W-CDMA terminals.

If complete control of all W-CDMA parameters is required, the HSDPA/HSUPA IQproducer MX269901A software (sold separately) can be used. For details, see the MX269901A section of this document.

Downlink Settings

Downlink sets parameters including Scrambling code, CPICH/P-CCPCH/PICH/DPCH power, Channelization code, DPCH_PhyCH TFCI and Timing Offset, and DPCH_TrCH Data to create the waveform pattern. (For details, see the Downlink Parameter Setting Range table described later.)

Additionally, the Downlink Easy Setup function supports the Reference Measurement Channel (RMC) items specified by 3GPP TS 25.101 and TS 25.104. Parameter setting is easy just by selecting the items to create the waveform pattern.

Easy Setup Items include:

- RMC 12.2 kbps (Rx test)
- RMC 12.2 kbps (Performance test)
- RMC 64 kbps (Performance test)
- RMC 144 kbps (Performance test)
- RMC 384 kbps (Performance test)

Uplink Settings

Uplink sets parameters including Scrambling code, UL-DPCCH/UL-DPDCH power, DPCH_PhyCH TFCI and Timing Offset, and DPCH_TrCH Data to create the waveform pattern. (For details, see the Uplink Parameter Setting Range table described later.)

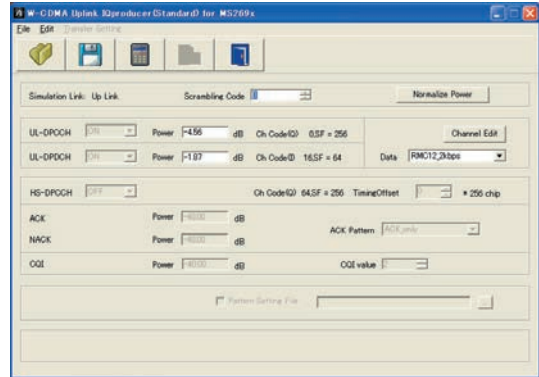

Uplink Main Screen

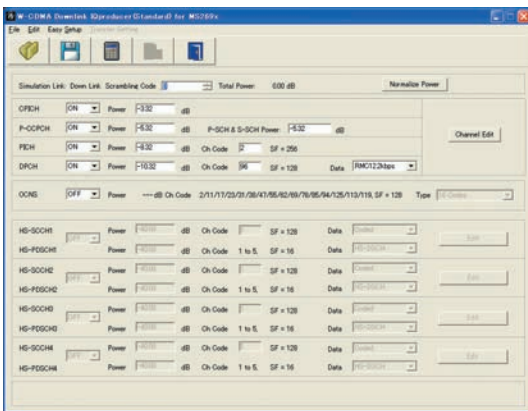

Downlink Main Screen

Downlink Parameter Setting Range

Display	Setting Range	
Scrambling Code		0 to 8191
CPICH	ON/OFF	ON or OFF
	Power	-40.00 to 0.00 dB, Resolution 0.01 dB
P-CCPCH	ON/OFF	ON or OFF
	Power	-40.00 to 0.00 dB, Resolution 0.01 dB
	P-SCH & S-SCH Power	-40.00 to 0.00 dB, Resolution 0.01 dB
PICH	ON/OFF	ON or OFF
	Power	-40.00 to 0.00 dB, Resolution 0.01 dB
	Channelization Code	0 to 255
DPCH	ON/OFF	ON or OFF
	Power	-40.00 to 0.00 dB, Resolution 0.01 dB
	Channelization Code	0 to SF-1 The spreading factor (SF) varies with the [Data] setting as follows: RMC 12.2 kbps = 128 RMC 64 kbps = 32 RMC 144 kbps = 16 RMC 384 kbps = 8 AMR1, AMR2, AMR3 = 128 ISDN = 32 384 kbps Packet = 8
	Data	RMC 12.2 kbps, RMC 64 kbps, RMC 144 kbps, RMC 384 kbps, AMR1, AMR2, AMR3, ISDN, 384 kbps Packet
OCNS	ON/OFF	ON or OFF
	Type	16 Codes
P-CCPCH Edit	SFN Cycle	Short
DPCH Edit (Phy CH)	TFCI	0 to 1023
	Timing Offset	0 to 149
DPCH Edit (TrCH Edit)	Data	PN9, PN9fix, PN15fix, 16bit repeat

Uplink Parameter Setting Range

Display	Setting Range	
Scrambling Code		0 to 16777215
UL-DPCCH, UL-DPDCH	Power	-40.00 to 0.00 dB
	Data	RMC 12.2 kbps, RMC 64 kbps, RMC 144 kbps, RMC 384 kbps, AMR1, AMR2, AMR3, ISDN, 64 kbps Packet
DPCH Edit (Phy CH)	TFCI	0 to 1023
	Timing Offset	0 to 149
DPCH Edit (TrCH Edit)	Data	PN9, PN9fix, PN15fix, 16bit repeat
Channel Gain	Beta c	0 to 15
	Beta d	0 to 15

This optional GUI-based PC application software is used to set parameters and generate waveform patterns for 3GPP HSDPA/HSUPA (Uplink/Downlink) systems.

If complete control of all W-CDMA parameters is required, the HSDPA/HSUPA IQproducer MX269901A software (sold separately) can be used. For details, see the MX269901A section of this document.

Once created, the waveform pattern file is downloaded to the MS269xA or MS2830A hard drive. Using the MS269xA-020 or MS2830A-020/021, Vector Signal Generator Option functionality, the files are loaded, selected, and output as a modulated RF signal. The HS-PDSCH and HS-DPCCH parameters specified in TS 25.212 can be set. The Downlink Easy Setup function assigns default values to some parameters and sets other items to typical values, making the creation of an accurate waveform pattern fast and easy.

Downlink Settings

Various downlink parameters can be set. (For details, see the Downlink Parameter Setting table described later.)

The Downlink Easy Setup function supports the HSDPA Fixed Reference Channel (FRC) items specified in 3GPP TS 25.101, and the Reference Measurement Channel (RMC) items specified in 3GPP TS 25.101 and TS 25.104.

Easy Setup Items include:

- FRC: H-Set1 (QPSK)
- H-Set1 (16QAM)
- H-Set2 (QPSK)
- H-Set2 (16QAM)
- H-Set3 (QPSK)
- H-Set3 (16QAM)
- H-Set4
- H-Set5
- RMC: RMC 12.2 kbps (Rx test)
- RMC 12.2 kbps (Performance test)
- RMC 64 kbps (Performance test)
- RMC 144 kbps (Performance test)
- RMC 384 kbps (Performance test)

Uplink Settings

Uplink sets parameters for UL-DPCCH/UL-DPDCH and HS-DPCCH channels and generates waveform patterns.

(For details, see the Uplink Parameter Setting Range table described later).

- HS-DPCCH (ACK, NACK, CQI)
- UL-DPCCH
- UL-DPDCH
- E-DPCCH
- E-DPDCH (s)

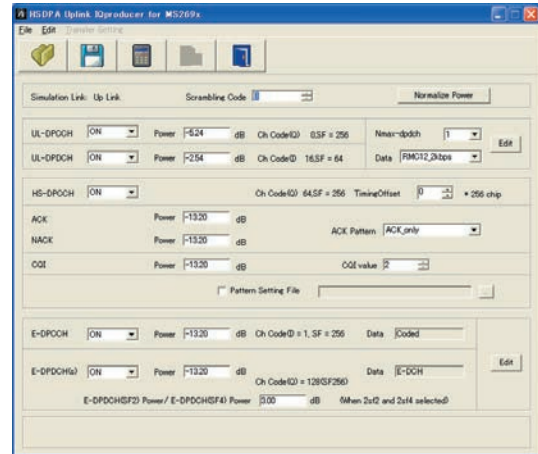

Uplink Main Screen

Parameter Save/Recall

The numeric values and settings for each item can be saved in a parameter file. Enter the file name in the [File name] field and click the [Save] button to save the parameter file.

A saved parameter file is recalled by selecting it in the file list and clicking the [Open] button.

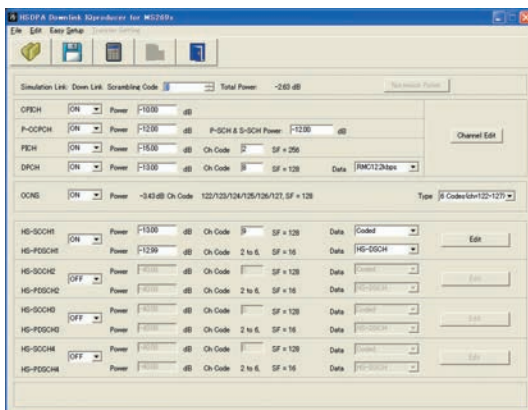

Downlink Main Screen

Downlink Parameter Setting Range

Display	Setting Range	
Scrambling Code		0 to 8191
CPICH	ON/OFF	ON or OFF
	Power	-40.00 to 0.00 dB, Resolution 0.01 dB
P-CCPCH	ON/OFF	ON or OFF
	Power	-40.00 to 0.00 dB, Resolution 0.01 dB
	P-SCH & S-SCH Power	-40.00 to 0.00 dB, Resolution 0.01 dB
PICH	ON/OFF	ON or OFF
	Power	-40.00 to 0.00 dB, Resolution 0.01 dB
	Channelization Code	0 to 255
DPCH	ON/OFF	ON or OFF
	Power	-40.00 to 0.00 dB, Resolution 0.01 dB
	Channelization Code	0 to SF-1 The spreading factor (SF) varies with the [Data] setting as follows: <ul style="list-style-type: none"> • RMC 12.2 kbps = 128 • RMC 64 kbps = 32 • RMC 144 kbps = 16 • RMC 384 kbps = 8 • AMR1, AMR2, AMR3 = 128 • ISDN = 32 • 384 kbps Packet = 8 • User Edit TrCH = Spreading Factor of Channel Edit screen
	Data	RMC 12.2 kbps, RMC 64 kbps, RMC 144 kbps, RMC 384 kbps, AMR1, AMR2, AMR3, ISDN, 384 kbps Packet, User Edit TrCH
OCNS	ON/OFF	ON or OFF
	Type	16 Codes or 6 Codes (ch = 122 to 127) or 6 Codes (ch = 2 to 7)
HS-SCCH1/2/3/4	ON/OFF	ON or OFF
	Power	-40.00 to 0.00 dB, Resolution 0.01 dB
	Channelization Code	0 to 127
	Data	PN9, PN9fix, PN15fix, 16bit repeat, Coded
HS-PDSCH1/2/3/4	ON/OFF	ON or OFF
	Power	-40.00 to 0.00 dB, Resolution 0.01 dB
	Channelization Code	0 to 15
	Data	PN9, PN9fix, PN15fix, 16bit repeat, HS-DSCH
P-CCPCH Edit	SFN Cycle	Short
DPCH Edit (Phy CH)	DPCH Data	PN9, PN9fix, PN15fix, 16bit repeat, TrCH
	TFCI	0 to 1023
	Spreading Factor	4, 8, 16, 32, 64, 128, 256, 512
	BER	0.0 to 100.0%
	Slot Format	#0 to #16
	Timing Offset	0 to 149
	TPC Edit	0000 0000 0000 0000 0000 0000 0000 0000 0000 0000 0000 0000 0000 0000 0000 0000 to 1111 1111 1111 1111 1111 1111 1111 1111 1111 1111 1111 1111 1111 1111 1111 1111
DPCH Edit (TrCH Edit)	TrCH Number	1 to 8
	DTX	Fix/Flex
	Data	PN9, PN9fix, PN15fix, 16bit repeat
	TTI	10, 20, 40, 80 ms
	Max. TrBk Size	0 to 5000
	TrBk Size	0 to 5000
	Max. TrBk Set No.	0 to 64
	TrBk Set No.	0 to 64
	CRC	0, 8, 12, 16, 24 bit
	Coder	CC1/2, CC1/3, TC
	RM attribute	1 to 256
	BER	0.0 to 100.0%
	BLER	0 to 100%
HSDPA transport channel (HS-SCCH, HS-PDSCH parameters)	Channelization Code Offset	1 to (16-Number of Physical Channel Code)
	Number of Physical Channel Code	1 to (16-Channelization Code Offset)
	Modulation	QPSK or 16QAM
	Transport Block Size Information	0 to 63
	RV Information	0 to 7
	UE Identity	0 to 65535
	CRC Error Insertion	Correct or Fail
	Number of HARQ Processes	0 to 8
	Virtual IR Buffer Size	800 to 304000
Payload Data	PN9, PN9fix, PN15fix, 16bit repeat	
Transmitting Pattern Edit	HARQ Process Cycle	1 to 16 (Note ranges from 1 to 6 when PN9 set for Payload Data)
	Inter-TTI Distance	1 to 8
	TTI Start Offset	0 to 7
	Process Setting File	Used or Not used

Uplink Parameter Setting Range

Display	Setting Range	
Scrambling Code	0 to 16777215	
UL-DPCCH, UL-DPDCH	Channel ON/OFF	ON or OFF
	Power	-40.00 to 0.00 dB, Resolution 0.01 dB
	Nmax-dpdch	0, 1
	Data	RMC 12.2 kbps, RMC 64 kbps, RMC 144 kbps, RMC 384 kbps, AMR1, AMR2, AMR3, ISDN, 64 kbps Packet, User Edit TrCH
HS-DPCCH	ON/OFF	ON or OFF
	Timing Offset	0 to 149
	ACK Power	-40.00 to 0.00 dB, Resolution 0.01 dB
	NACK Power	-40.00 to 0.00 dB, Resolution 0.01 dB
	CQI Power	-40.00 to 0.00 dB, Resolution 0.01 dB
	ACK Pattern	ACK_only, NACK_only, alt_ACK_NACK_DTX
	CQI value	0 to 30
	Pattern Setting File	Used or Not used
E-DPCCH, E-DPDCH	E-DPCCH ON/OFF	ON or OFF
	E-DPDCH ON/OFF	ON or OFF
	E-DPCCH Power	-40.00 to 0.00 dB, Resolution 0.01 dB
	E-DPDCH Power	-40.00 to 0.00 dB, Resolution 0.01 dB
	E-DPDCH (SF2) Power/ E-DPDCH (SF4) Power	-10.00 to +10.00 dB, Resolution 0.01 dB
DPCCH Edit (Phy CH)	UL-DPDCH Data	PN9, PN9fix, PN15fix, 16bit repeat, TrCH
	TFCI	0 to 1023
	Spreading Factor	4, 8, 16, 32, 64, 128, 256
	BER	0.0 to 100.0% (Enabled when [Data] set to [PN9])
	Slot Format	#0 to #1
	Timing Offset	0 to 149
	TPC Edit	0000 0000 0000 0000 0000 0000 0000 0000 0000 0000 0000 0000 0000 0000 0000 0000 to 1111 1111 1111 1111 1111 1111 1111 1111 1111 1111 1111 1111 1111 1111 1111 1111
DPCCH Edit (TrCH Edit)	TrCH Number	1 to 8
	Data	PN9, PN9fix, PN15fix, 16bit repeat
	TTI	10, 20, 40, 80 ms
	Max. TrBk Size	0 to 5000
	TrBk Size	0 to 5000
	Max. TrBk Set No.	0 to 64
	TrBk Set No.	0 to 64
	CRC	0, 8, 12, 16, 24 bit
	Coder	CC1/2, CC1/3, TC
	RM attribute	1 to 256
	BER	0.0 to 100.0% (Enabled when [Data] set to [PN9])
	BLER	0 to 100% (Enabled when [Data] set to [PN9])
E-DPDCH and E-DPCCH Edit (Phy CH)	HARQ Process Setting File	Common dialog opens when the check box is checked HARQ Process Setting File can be selected
	E-DPCCH Data	PN9, PN9fix, PN15fix, 16bit repeat, Coded
	E-DPDCH Data	PN9, PN9fix, PN15fix, 16bit repeat, E-DCH
	HS-DSCH Configured	Yes, No
	E-DPDCH Channel Codes	SF256, SF128, SF64, SF32, SF16, SF8, SF4, 2SF4, 2SF2, 2SF2 and 2SF4
E-DPDCH and E-DPCCH Edit (Tr CH)	E-DCH TTI	2, 10 ms
	Information Bit Payload	18 to 11484 (at E-DCH TTI = 2 ms) 18 to 20000 (at E-DCH TTI = 10 ms)
	E-DCH Payload Data	PN9, PN9fix, PN15fix, 16bit repeat
	E-TFCI Information	0 to 127
	RSN	0 to 3
	Pattern Length	Display only
	E-DCH RV Index	0 to 3
	CRC Error Insertion	Correct, Error
"Happy" Bit	0, 1	

TDMA IQproducer MX269902A

Optional

MS269xA

MS2840A

MS2830A

This optional GUI-based PC application software is used to set the parameters and generate waveform patterns for TDMA systems. Once created, the waveform pattern file is downloaded to the MS269xA or MS2840A/MS2830A hard drive. Using the MS269xA-020 or MS2840A/MS2830A-020/021, Vector Signal Generator Option functionality, the files are loaded, selected, and output as a modulated RF signal. In addition to signals supporting PDC, PHS, ARIB STD-T61/T79/T86/T98/T102, Advanced-PHS, ETC and DSRC systems, signals for other systems can also be generated.

Graphical Simulation Displays

This function displays a generated waveform as a Complementary Cumulative Distribution Function (CCDF) and Fast Fourier Transform (FFT) on the PC.

It is useful for checking or reviewing waveforms.

CCDF Graph

Up to eight generated waveform patterns can be read and displayed as CCDF graphs.

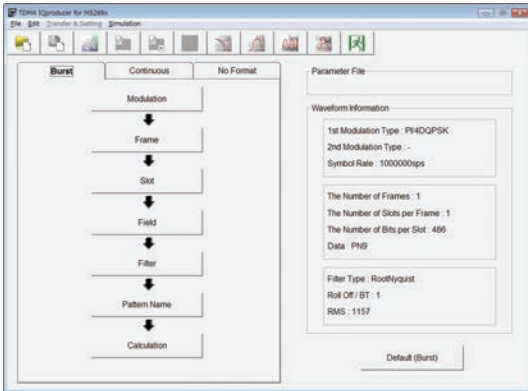

Main Screen

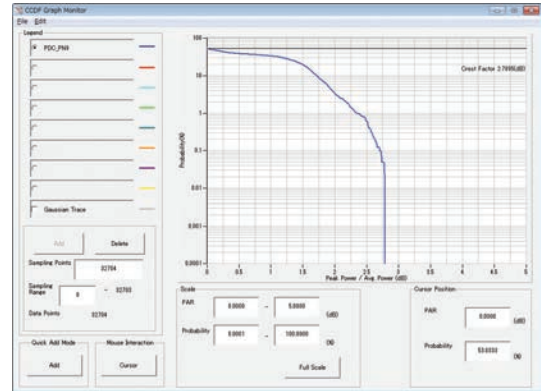

CCDF Graph Screen

Parameter Setting Items List

Setting	Parameter Setting Sheet		
	Burst	Continuous	No Format
Modulation	✓	✓	✓
Frame	✓	✓	-
Slot	✓	✓	-
Field	✓	✓	-
Data	-	-	✓
Filter	✓	✓	✓
Pattern Name	✓	✓	✓
Calculation	✓	✓	✓

FFT Graph

Up to four generated waveform patterns can be read and displayed as FFT graphs.

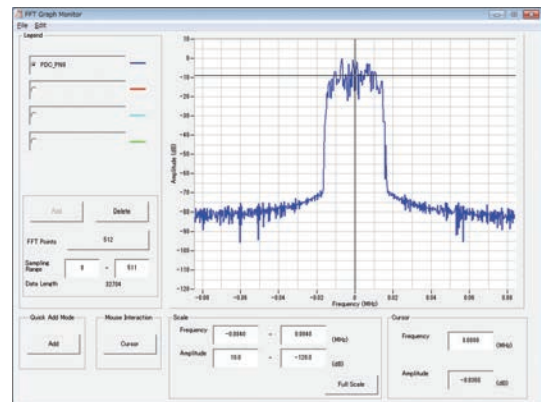

FFT Graph Screen

Parameter Save/Recall

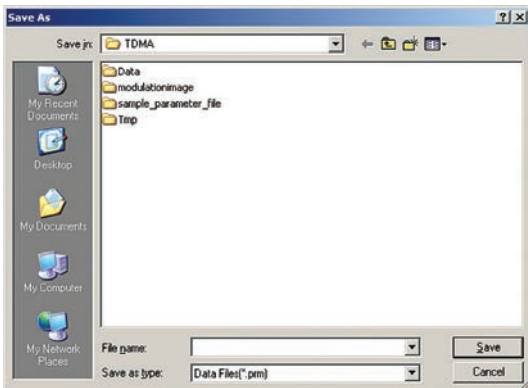

The numeric values and settings for each item can be saved in a parameter file. Enter the file name in the [File name] field and click the [Save] button to save the parameter file.

A saved parameter file is recalled by selecting it in the file list and clicking the [Open] button.

Parameter Setting Items List

Items	Display	Outline	Setting Range
Modulation	Modulation Type (1st Modulation Type)	1st Modulation Type	BPSK, DBPSK, PI/2DBPSK, QPSK, O-QPSK, DQPSK, PI/4DQPSK, 8PSK*1, D8PSK*1, 16QAM*1, 32QAM*1, 64QAM*1, 256QAM*1, ASK, 2FSK, 4FSK, 4ASK
	Modulation Type (2nd Modulation Type)	2nd Modulation Type	BPSK, DBPSK, PI/2DBPSK, QPSK, DQPSK, PI/4DQPSK, 8PSK, D8PSK, 16QAM, 32QAM, 64QAM, 256QAM
	Symbol Rate	Symbol Rate	1 kspss to 80 Msps (can be set in the 1 sps units)
	Over Sampling	Over Sampling Rate	2, 3, 4, 8, 16, 32
	Sampling Rate	Sampling Rate	20 kHz to 160 MHz (The value of symbol rate × over sampling rate is set automatically. However, when the Manchester code setting enabled, the value of symbol rate × over sampling rate × 2 is set automatically)
	GSM	GSM Setting	Enable/disable automatic setting in accordance with GSM (Enabled when 8PSK or 2FSK set as modulation type)
	Modulation Index	Modulation Index	0.00 to 1.00 (for ASK), 0.20 to 10.00 (for 2FSK)
	Manchester Code	Manchester Code	The Manchester code is selected when this checkbox is selected, and NRZ is selected when this checkbox is cleared. NRZ is always selected for modulation types other than ASK
Maximum Frequency Deviation	Maximum frequency deviation	120 to 2100	
Frame	The Number of Frames	Frame number	1 to 4088, Auto
	The Number of Slots per Frame	Slot numbers in one frame	1 to 20
Slot (Burst)	1, 24 field	Guard field	Set the number of bits listed in the separate table according to Modulation Type.
	2, 23 field	Ramp field	Set the number of bits listed in the separate table according to Modulation Type.
	3 to 22 field	Fixed (Fixed data) field	Set integer from 0 to 128.
	3 to 22 field	Data (PN9, PN15) field	Set integer from 0 to 1024.
	4 to 22 field	CRC (Cyclic Redundancy Check character) field	0, 8, 12, 16, 24, 32
Slot (Continuous)	1 to 24 field	Fixed (Fixed data) field	Set integer from 0 to 128.
	1 to 24 field	Data (PN9, PN15) field	Set integer from 0 to 1024.
	2 to 24 field	CRC (Cyclic Redundancy Check character) field	0, 8, 12, 16, 24, 32
Field (Burst/Continuous)	Fixed	Sets hexadecimal fixed data	0 to maximum value of number of bits set
	CRC	Sets CRC calculation field as integer	1 to number of bits in field on left to CRC (except Guard and Ramp fields)
	Data Field	Selects continuous pattern	PN9, PN15, 16 bit Pattern, All 0, All 1, UserFile*2 Input any hexadecimal number for 16 bit Pattern.
Data (No Format)	Data	Selects continuous pattern	PN9, PN15, 16 bit Pattern, All 0, All 1, UserFile*2
Filter	Filter	Filter type	Nyquist, Root Nyquist, Gaussian, Gaussian2, Ideal Lowpass, None, ARIB STD-T98, ARIB STD-T102 Part1, Half-sine, User Defined Filter
	Roll Off/BT	Roll off rate/BT product	0.10 to 1.00 (When Nyquist/Root Nyquist/Gaussian is set)
	Passband	Passband of filter	Fs/2, Fs/3, Fs/4, Fs/8, Fs/16, Fs/32 (This item is displayed and can be set only when Ideal Lowpass is set as the filter type. The setting range varies with the over sampling rate)
	RMS	RMS value of waveform pattern data	1157
Pattern Name	Package	Package name	Within 31 characters
	Pattern Name	Waveform pattern file name	Within 20 characters
	Comment	Comment	Within 38 characters
Calculation	Starts waveform pattern data generation after setting parameters.		

*1: Decimal numbers for each symbol point are changed by selecting a user file for IQ mapping.

*2: When "UserFile" is set, the binary sequence is read from a text file. Up to 9,600,000 bits can be loaded and then modulated.

Guard Field Setting Range

(1st/2nd) Modulation Type	Number of Bits in 1st Field	Number of Bits in 24th Field
BPSK, DBPSK, PI/2DBPSK, ASK, 2FSK	Integer between 0 and 9960	Integer between 0 and 9960
QPSK, O-QPSK, DQPSK, PI/4DQPSK, 4FSK, 4ASK	Multiples of 2 between 0 and 9960	Multiples of 2 between 0 and 9960
8PSK, D8PSK	Multiples of 3 between 0 and 9960	Multiples of 3 between 0 and 9960
16QAM	Multiples of 4 between 0 and 9960	Multiples of 4 between 0 and 9960
32QAM	Multiples of 5 between 0 and 9960	Multiples of 5 between 0 and 9960
64QAM	Multiples of 6 between 0 and 9960	Multiples of 6 between 0 and 9960
256QAM	Multiples of 8 between 0 and 9960	Multiples of 8 between 0 and 9960

Ramp Field Setting Range

(1st/2nd) Modulation Type	Number of Bits
BPSK, DBPSK, PI/2DBPSK, ASK, 2FSK	Integer number between 1 and 16
QPSK, O-QPSK, DQPSK, PI/4DQPSK, 4FSK, 4ASK	Multiples of 2 between 2 and 32
8PSK, D8PSK	Multiples of 3 between 3 and 48
16QAM	Multiples of 4 between 4 and 64
32QAM	Multiples of 5 between 5 and 80
64QAM	Multiples of 6 between 6 and 96
256QAM	Multiples of 8 between 8 and 128

Multi-Carrier IQproducer MX269904A

Optional

MS269xA

MS2840A

MS2830A

This GUI-driven PC application software is used to create a multi-carrier waveform pattern for modulated signals and tone signals of communications systems. Once created, the waveform pattern file is downloaded to the MS269xA or MS2840A/MS2830A hard drive. Using the MS269xA-020 or MS2840A/MS2830A-020/021, Vector Signal Generator Option functionality, the files are loaded, selected, and output as a multi-carrier RF signal. W-CDMA downlink multi-carrier signals are supported as well as various types of clipping.

Multi-purpose Function

By using the multi-carrier function, a signal with up to 32 carriers can be converted to a single waveform pattern. While it may not be possible to set 32 carriers due to the frequency offset and the waveform pattern, it is possible to create a waveform pattern with more than 32 carriers by combining multi-carrier waveform patterns.

Ex) 10 MHz Bandwidth WiMAX × 2 carrier

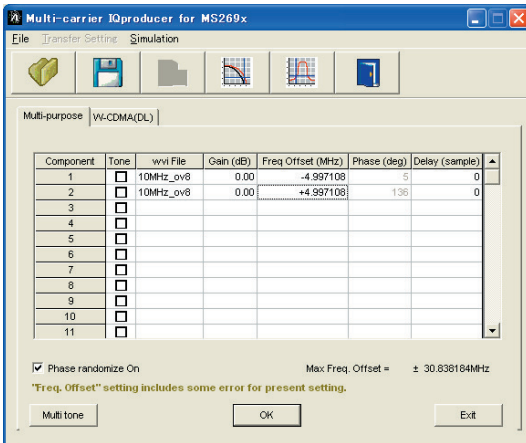

Multi-carrier Setting Screen

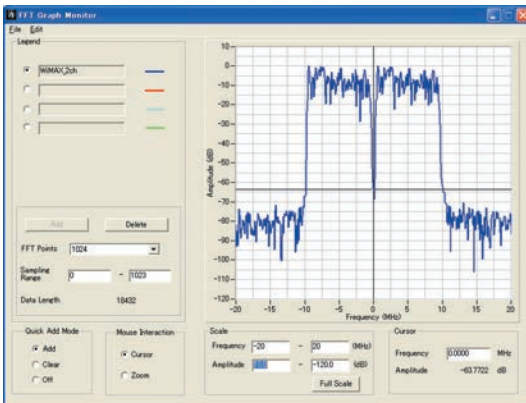

FFT Analysis Screen

W-CDMA (DL) Function

This function is used to create a waveform pattern by setting any of the 4 or 5 carriers of the W-CDMA Downlink ON/OFF, as well as by setting the Clipping Method, Clipping Reference Level, and Clipping Ratio.

Carrier Type

- Test Model 1 16DPCH, Test Model 1 32DPCH,
- Test Model 1 64DPCH,
- Test Model 5 2HS-PDSCH, Test Model 5 4HS-PDSCH,
- Test Model 5 8HS-PDSCH

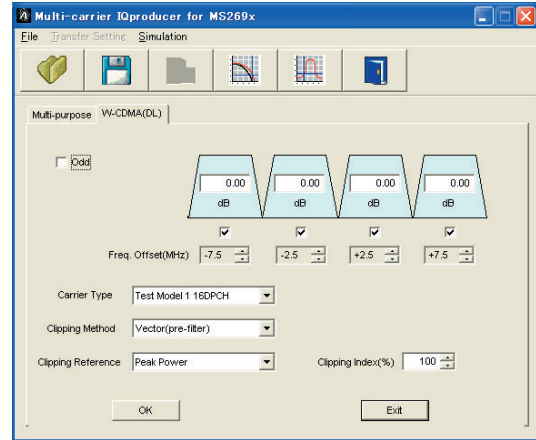

Multi-carrier Setting Screen

Clipping Method

- Non, Vector (pre-filter), Vector (post-filter),
- Scalar (pre-filter), Scalar (post-filter)

Clipping Reference level

- Peak Power, RMS Power

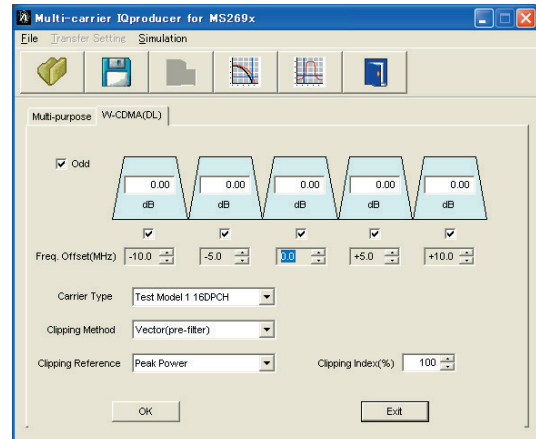

Multi-carrier Setting Screen

This GUI-driven PC application software is used to set parameters and generate waveform patterns based on the IEEE 802.16e-2005 WirelessMAN-OFDMA standard. Signals that comply with this particular specification are also known as mobile WiMAX signals. Once created, the waveform pattern file is downloaded to the MS269xA or MS2830A hard drive. Using the MS269xA-020 or MS2830A-020/021, Vector Signal Generator Option functionality, the files are loaded, selected, and output as a modulated WiMAX signal. Permutation zones and user bursts are easy to configure in a frame using drop-and-drag functionality in a user-friendly GUI. Modulation, coding type, and coding rate can be set for each user burst. Most receiver tests described in IEEE 802.16e-2005 (Section 8.4.13, Receiver Requirement) can be performed except those functional tests requiring equipment other than a Signal Generator.

Parameter Save/Recall

The numeric values and settings for each item can be saved in a parameter file. Enter the file name in the [File name] field and click the [Save] button to save the parameter file. A saved parameter file is recalled by selecting it in the file list and clicking the [Open] button.

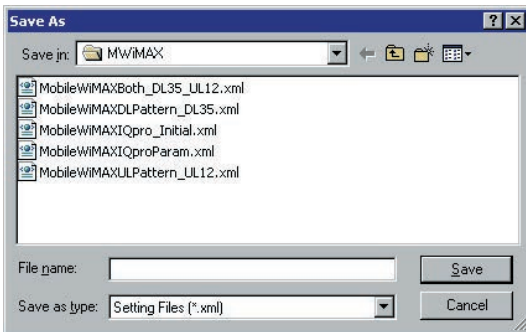

Graphical Simulation Displays

Clipping, filtering, and checking can be performed for created waveform patterns by displaying CCDF, FFT, and Time Domain graphs.

CCDF Graph

Up to eight generated waveform patterns can be read and displayed as CCDF graphs.

FFT Graph

Up to four generated waveform patterns can be read and displayed as FFT graphs.

Time Domain Graph Display

Up to four types of Time Domain graph can be displayed when reading created waveform patterns.

Clipping Function

Clipping and filtering can be performed for created waveform patterns.

This tree displays PHY/MAC parameters. The following items can be added and deleted:
DCD, UCD, Downlink, Uplink, Preamble, FCH, MAC Message, Zone, Burst, MAC PDU, DL-MAP, UL-MAP.

Parameters for items selected in the tree on the left and at the Segment Edit screen are set here.

Parameters such as physical layers and filters, are set here.

Error Message Area

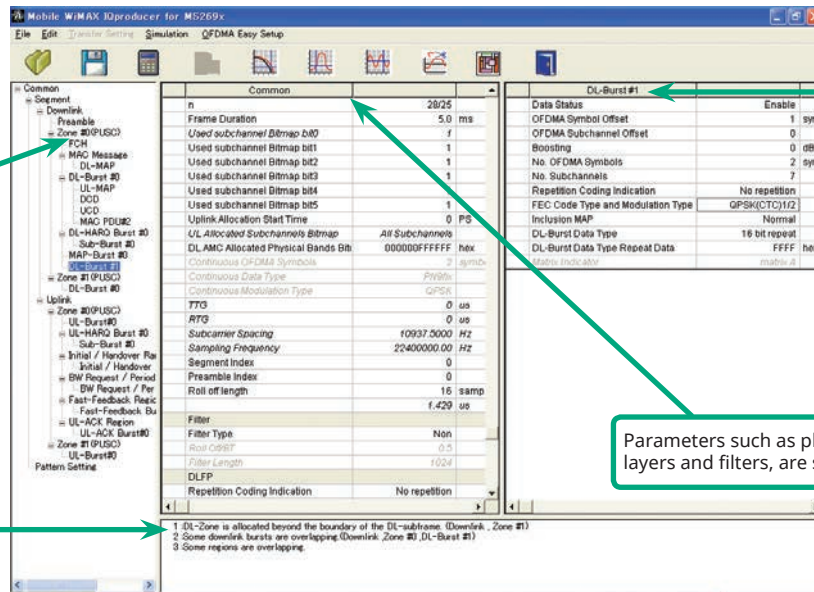

Mobile WiMAX IQproducer Main Screen

Excellent Operability: Segment Edit Screen

- The magnified or reduced Zone or Burst can be edited using the drop-and drag techniques.
- The editing result is reflected in the Main screen parameters.
- An information window opens to describe parameters of any selected area.
- Parameters for the selected area are displayed on the Main screen.

This button displays the Segment Edit screen for checking and editing the Segment MAP.

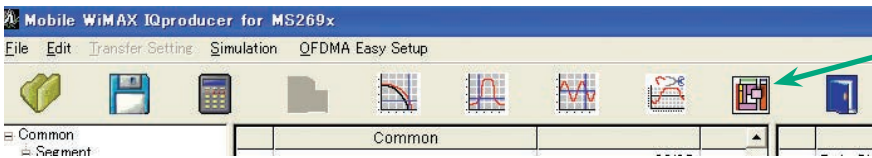

Mobile WiMAX IQproducer Main Screen

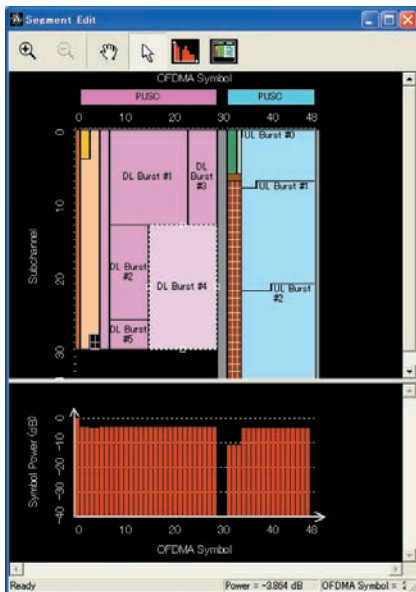

Segment Edit Screen

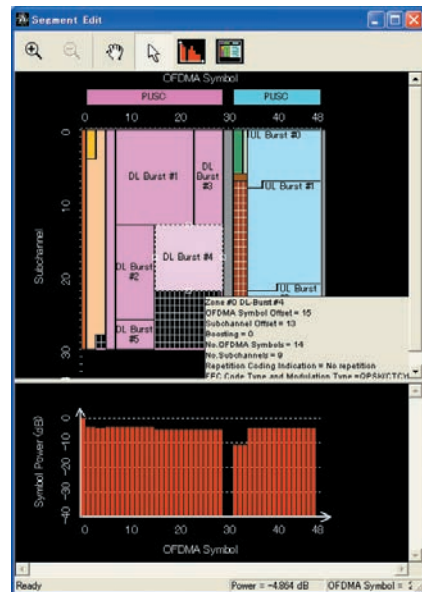

Segment Edit Screen

Common Parameter Setting Range

Tree	Items	Setting Range	Frame Duration = Continuous	
Common	Number of Tx Antennas	1, 2		
	Number of Frames	1 to Maximum number of Frame saved in memory	Cannot be set	
	Initial Frame Number	000000 to FFFFFFFF (HEX)	Cannot be set	
	FFT size	128, 512, 1024, 2048		
	G (CP Time Ratio)	1/4, 1/8, 1/16, 1/32		
	Over Sampling Ratio	2, 4, 8		
	Bandwidth	1.25, 1.50, 1.75, 2.50, 3.00, 3.50, 5.00, 6.00, 7.00, 8.75, 10.00, 12.00, 14.00, 15.00, 17.50, 20.00, 24.00, 28.00 MHz		
	n (Sampling Factor)	8/7, 28/25		
	Frame Duration	2.0, 2.5, 4.0, 5.0, 8.0, 10.0, 12.5, 20.0 ms, Continuous		
	Used subchannel Bitmap bit0 to bit5	1, 0: When FFT size = 128, 512, bit 0, 2, 4 = 0 When Segment Index = 0, bit 0 = 1; when Segment Index = 1, bit 2 = 1, when Segment Index = 2, bit 4 = 1 Cannot be set when DL Use All SC Indicator = All		
	Uplink Allocation Start Time	0 to Frame EndPS (Cannot be set when neither of Downlink/Uplink not in tree)	Cannot be set	
	Uplink Allocation Subchannels Bitmap	All Subchannels		
	DL AMC Allocated Physical Bands Bitmap	FFT size = 2048	000000000000 to FFFFFFFF	
		FFT size = 1024	000000000000 to 000000FFFFFF	
		FFT size = 512	000000000000 to 000000000FFF	
		FFT size = 128	000000000000 to 000000000007	
	Continuous OFDMA Symbols	2 to maximum number of OFDMA Symbol in memory (2 symbol step):	Cannot be set	
	Continuous Data Type	16bit repeat, PN9fix, PN15fix, S_QPSK, S_16QAM, S_64QAM, User File: Coding, and Randomization cannot be set at data selected here	Cannot be set	
	Continuous Data Type Repeat Data	0000 to FFFF (HEX): Can be set when Continuous Data Type = 16bit repeat	Cannot be set	
	Continuous Data Type User File	User File selected: Can be set when Continuous Data Type = User File	Cannot be set	
	Continuous Modulation Type	QPSK, 16QAM, 64QAM: Can be set when Frame Duration = Continuous	Cannot be set	
	TTG	Display only: Gap interval between Downlink and Uplink displayed		
	RTG	Display only: Gap interval between Uplink and Frame End displayed		
	Subcarrier Spacing	Display only		
	Sampling Frequency	Display only: Depends on Bandwidth, n (Sampling Factor), and Over Sampling Ratio		
	Segment Index	0, 1, 2	Cannot be set	
	Preamble Index	<Table 1>	Cannot be set	
	Roll off length	0 to 32		
	Filter			
	Filter Type	Non, Gaussian, Root Nyquist, Nyquist, Ideal		
	Roll Off/BT	0.1 to 1.0: Cannot be set when Filter Type = Non, Ideal		
	Filter Length	1 to 1024: Cannot be set when Filter Type = Non, Ideal		
	DLFP			
Repetition Coding Indication	No repetition, 2, 4, 6	Cannot be set		
Coding Indication	CC, CTC	Cannot be set		
DIUC Setting	Auto, Manual			
DIUC List	QPSK (CC) 1/2, QPSK (CC) 3/4, 16QAM (CC) 1/2, 16QAM (CC) 3/4, 64QAM (CC) 1/2, 64QAM (CC) 2/3, 64QAM (CC) 3/4, QPSK (CTC) 1/2, QPSK (CTC) 3/4, 16QAM (CTC) 1/2, 16QAM (CTC) 3/4, 64QAM (CTC) 1/2, 64QAM (CTC) 2/3, 64QAM (CTC) 3/4, 64QAM (CTC) 5/6			
UIUC Setting	Auto, Manual			
UIUC List	QPSK (CC) 1/2, QPSK (CC) 3/4, 16QAM (CC) 1/2, 16QAM (CC) 3/4, 64QAM (CC) 1/2, 64QAM (CC) 2/3, 64QAM (CC) 3/4, QPSK (CTC) 1/2, QPSK (CTC) 3/4, 16QAM (CTC) 1/2, 16QAM (CTC) 3/4, 64QAM (CTC) 1/2, 64QAM (CTC) 2/3, 64QAM (CTC) 3/4, 64QAM (CTC) 5/6			
Segment	Multi-Path Setting	Enable, Disable		
	Tx Antenna0, 1	Multi-Path Number: 1 to 20 Delay: 0.0 to 10000.0 ns Gain: -80.0 to 0.0 dB Phase: 0.0 to 359.9°		

Table 1: Preamble Index Setting Range

When Segment Index = 0	When Segment Index = 1	When Segment Index = 2
0 (IDcell = 0), 1 (IDcell = 1), 2 (IDcell = 2), 3 (IDcell = 3), 4 (IDcell = 4), 5 (IDcell = 5), 6 (IDcell = 6), 7 (IDcell = 7), 8 (IDcell = 8), 9 (IDcell = 9), 10 (IDcell = 10), 11 (IDcell = 11), 12 (IDcell = 12), 13 (IDcell = 13), 14 (IDcell = 14), 15 (IDcell = 15), 16 (IDcell = 16), 17 (IDcell = 17), 18 (IDcell = 18), 19 (IDcell = 19), 20 (IDcell = 20), 21 (IDcell = 21), 22 (IDcell = 22), 23 (IDcell = 23), 24 (IDcell = 24), 25 (IDcell = 25), 26 (IDcell = 26), 27 (IDcell = 27), 28 (IDcell = 28), 29 (IDcell = 29), 30 (IDcell = 30), 31 (IDcell = 31), 96 (IDcell = 0), 99 (IDcell = 3), 102 (IDcell = 6), 105 (IDcell = 9), 108 (IDcell = 12), 111 (IDcell = 15)	32 (IDcell = 0), 33 (IDcell = 1), 34 (IDcell = 2), 35 (IDcell = 3), 36 (IDcell = 4), 37 (IDcell = 5), 38 (IDcell = 6), 39 (IDcell = 7), 40 (IDcell = 8), 41 (IDcell = 9), 42 (IDcell = 10), 43 (IDcell = 11), 44 (IDcell = 12), 45 (IDcell = 13), 46 (IDcell = 14), 47 (IDcell = 15), 48 (IDcell = 16), 49 (IDcell = 17), 50 (IDcell = 18), 51 (IDcell = 19), 52 (IDcell = 20), 53 (IDcell = 21), 54 (IDcell = 22), 55 (IDcell = 23), 56 (IDcell = 24), 57 (IDcell = 25), 58 (IDcell = 26), 59 (IDcell = 27), 60 (IDcell = 28), 61 (IDcell = 29), 62 (IDcell = 30), 63 (IDcell = 31), 97 (IDcell = 1), 100 (IDcell = 4), 103 (IDcell = 7), 106 (IDcell = 10), 109 (IDcell = 13), 112 (IDcell = 16)	64 (IDcell = 0), 65 (IDcell = 1), 66 (IDcell = 2), 67 (IDcell = 3), 68 (IDcell = 4), 69 (IDcell = 5), 70 (IDcell = 6), 71 (IDcell = 7), 72 (IDcell = 8), 73 (IDcell = 9), 74 (IDcell = 10), 75 (IDcell = 11), 76 (IDcell = 12), 77 (IDcell = 13), 78 (IDcell = 14), 79 (IDcell = 15), 80 (IDcell = 16), 81 (IDcell = 17), 82 (IDcell = 18), 83 (IDcell = 19), 84 (IDcell = 20), 85 (IDcell = 21), 86 (IDcell = 22), 87 (IDcell = 23), 88 (IDcell = 24), 89 (IDcell = 25), 90 (IDcell = 26), 91 (IDcell = 27), 92 (IDcell = 28), 93 (IDcell = 29), 94 (IDcell = 30), 95 (IDcell = 31), 98 (IDcell = 2), 101 (IDcell = 5), 104 (IDcell = 8), 107 (IDcell = 11), 110 (IDcell = 14), 113 (IDcell = 17)

PHY/MAC Parameter (Downlink) Setting Range

Tree	Items	Setting Range	
Downlink	Data Status	Enable, Disable	
Preamble	Data Status	Enable, Disable	
	Preamble Index	Display only: Set at Common.	
	IDcell	Display only: Depends on Preamble Index setting	
Zone#0 to #7	Data Status	Enable, Disable	
	Permutation	PUSC, PUSC (all SC), FUSC, AMC (6 × 1), AMC (3 × 2), AMC (2 × 3), AMC (1 × 6)	
	Pilot Position	Hopping, Center	
	Dedicated Pilot	0, 1	
	Pilot Boosting	OFF, ON	
	STC/MIMO	No transmit diversity, 2 Antenna Matrix A (STTD), 2 Antenna Matrix B vertical encoding	
	OFDMA Symbol Offset	<Zone#0> Display only <Zone#1 to #7> 0 to 255 symbol (without Preamble), 1 to 255 symbol (with Preamble)	
	No. OFDMA Symbols	2 to 254 symbol (when PUSC) 2 to 254 symbol (when PUSC1 (all SC)) 1 to 255 symbol (when FUSC) 1 to 255 symbol (when AMC (6 × 1)) 2 to 254 symbol (when AMC (3 × 2)) 3 to 255 symbol (when AMC (2 × 3)) 6 to 252 symbol (when AMC (1 × 6))	
	DL-PermBase	0 to 31 (Cannot be set at Zone#0)	
	DL-Burst Number	1 to 16	
	PRBS_ID	0 to 3 (Cannot be set at Zone#0)	
FCH	Data Status	Enable, Disable	
	FCH Type	16bit repeat, PN9fix, PN15fix, DLFP, User File	
	FCH Type Repeat Data	0000 to FFFF (HEX): Can be set when FCH Type = 16bit repeat	
	FCH Type User File	User File selected: Can be set when FCH Type = User File	
	Used subchannel Bitmap Bit 0 to Bit 5	Display only: Set at Common	
	Repetition Coding Indication	Display only: Set at Common	
	Coding Indication	Display only: Set at Common	
	DL-MAP Length	Display only: Set at DL-MAP	
	MAC Message	Data Status	Enable, Disable
DL-MAP		Data Status	Enable, Disable
		DL-MAP Type	16bit repeat, PN9fix, PN15fix, S_QPSK, S_16QAM, S_64QAM, DL-MAP, Compressed DL-MAP, User File
		DL-MAP Type Repeat Data	0000 to FFFF (HEX): Can be set DL-MAP Type = 16bit repeat
		DL-MAP Type User File	User File selected: Can be set when DL-MAP Type = User File
		DL-MAP Length	0 to 255 slot: The calculation value is displayed when DL-MAP Type = DL-MAP or Compressed DL-MAP The length of DL-MAP can be set in other cases
		DCD Count	0 to 255: Can be set when DL-MAP Type = DL-MAP or Compressed DL-MAP
		Base Station ID	0000 0000 0000 to FFFF FFFF FFFF (HEX): Can be set when DL-MAP Type = DL-MAP or Compressed DL-MAP
		DL-MAP PHY Synchronization Field	
		Frame Duration	Display only: Set at Common
		Initial Frame Number	Display only: Set at Common
		Zone# DL-MAP IE#	
		DIUC (Downlink Interval Usage Code)	0 to 12
		OFDMA Symbol Offset	Display only: Set at DL-Burst
		OFDMA Subchannel Offset	Display only: Set at DL-Burst
		Boosting	Display only: Set at DL-Burst
		No. OFDMA Symbol	Display only: Set at DL-Burst

Mobile WiMAX IQproducer MX269905A

Optional

MS269xA

MS2830A

Tree	Items	Setting Range	
DL-MAP (Cont'd)	No. Subchannels	Display only: Set at DL-Burst	
	Repetition Coding Indication	Display only: Set at DL-Burst	
	Zone# STC/Zone switch IE		
	OFDMA Symbol Offset	Enable, Disable	
	Permutation	Display only: Set at DL-Zone	
	DL Use All SC Indicator	Display only	
	DL-PermBase	Display only: Set at DL-Zone	
	SUB-DL-UL-MAP	Data Status	Enable, Disable
		OFDMA Symbol Offset	Display only
		OFDMA Subchannel Offset	Display only
		Length	Display only
		FEC Code Type and Modulation Type	QPSK (CC) 1/2, QPSK (CC) 3/4, 16QAM (CC) 1/2, 16QAM (CC) 3/4, 64QAM (CC) 1/2, 64QAM (CC) 2/3, 64QAM (CC) 3/4, QPSK (CTC) 1/2, QPSK (CTC) 3/4, 16QAM (CTC) 1/2, 16QAM (CTC) 3/4, 64QAM (CTC) 1/2, 64QAM (CTC) 2/3, 64QAM (CTC) 3/4, 64QAM (CTC) 5/6, QPSK (No Ch Coding), 16QAM (No Ch Coding), 64QAM (No Ch Coding)
		Repetition Coding Indication	No repetition, 2, 4, 6
		RCID Type	Normal CID, RCID11, RCID7, RCID3
		HARQ ACK offset indicator	0, 1
		DL HARQ ACK offset	0 to 255
		UL HARQ ACK offset	DL IE Count
		OFDMA Symbol Offset	0 to 255
OFDMA Subchannel Offset		0 to 127	
DL-Burst 0 to 15	Data Status	Enable, Disable	
	OFDMA Symbol Offset	<ul style="list-style-type: none"> • 0 to 254 symbol without Preamble at Zone#0 (Select by even symbol) • 1 to 255 symbol with Preamble at Zone#0 (Select by odd symbol) • (OFDMA Symbol Offset at Zone) to 255 symbol when PUSC Zone from Zone#1 to #7 • (OFDMA Symbol Offset at Zone) to 255 symbol when PUSC (all SC) Zone • (OFDMA Symbol Offset at Zone) to 255 symbol when FUSC Zone • (OFDMA Symbol Offset at Zone) to 255 symbol when AMC (6 × 1) Zone • (OFDMA Symbol Offset at Zone) to 255 symbol when AMC (3 × 2) Zone • (OFDMA Symbol Offset at Zone) to 255 symbol when AMC (2 × 3) Zone • (OFDMA Symbol Offset at Zone) to 255 symbol when AMC (1 × 6) Zone 	
	OFDMA Subchannel Offset	0 to 63 (when AMC (2 × 3), AMC (1 × 6) excluded) 0 to 255 (when AMC (2 × 3), AMC (1 × 6))	
	Boosting	-12, -9, -6, -3, 0, +3, +6, +9 dB	
	No. OFDMA Symbols	2 to 126 symbol (when PUSC) 2 to 126 symbol (when PUSC (all SC)) 1 to 127 symbol (when FUSC) 1 to 127 symbol (when AMC (6 × 1)) 2 to 126 symbol (AMC (3 × 2)) 3 to 93 symbol (when AMC (2 × 3)) 6 to 90 symbol (when AMC (1 × 6))	
	No. Subchannels	1 to 63	
	Repetition Coding Indication	No repetition, 2, 4, 6: Can be set when FEC Code Type and Modulation Type = QPSK (CC) 1/2, QPSK (CC) 3/4, QPSK (CTC) 1/2, QPSK (CTC) 3/4, QPSK (No Ch Coding); no repetition fixed in other cases	
	FEC Code Type and Modulation Type	QPSK (CC) 1/2, QPSK (CC) 3/4, 16QAM (CC) 1/2, 16QAM (CC) 3/4, 64QAM (CC) 1/2, 64QAM (CC) 2/3, 64QAM (CC) 3/4, QPSK (CTC) 1/2, QPSK (CTC) 3/4, 16QAM (CTC) 1/2, 16QAM (CTC) 3/4, 64QAM (CTC) 1/2, 64QAM (CTC) 2/3, 64QAM (CTC) 3/4, 64QAM (CTC) 5/6, QPSK (No Ch Coding), 16QAM (No Ch Coding), 64QAM (No Ch Coding)	
	Inclusion MAP	Normal, SUB-DL-UL-MAP#n (n = 0 to 2)	
	DL-Burst Data Type	16bit repeat, PN9fix, PN15fix, S_QPSK, S_16QAM, S_64QAM, MAC PDU, User File	
	DL-Burst Data Type Repeat Data	0000 to FFFF (HEX): Can be set when DL-Burst Data Type = 16bit repeat	
	DL-Burst Data Type User File	User File selected: Can be set when DL-Burst Data Type = User File	
	MAC PDU Number	0 to 32	
	Matrix Indicator	Matrix A, Matrix B	
	UL-MAP	Data Status	Enable, Disable
UL-MAP Type		16bit repeat, PN9fix, PN15fix, S_QPSK, S_16QAM, S_64QAM, UL-MAP, Compressed UL-MAP, User File	
UL-MAP Type Repeat Data		0000 to FFFF (HEX): Can be set when UL-MAP Type = 16bit repeat	
UL-MAP Type User File		User File selected: Can be set when UL-MAP Type = User File	
UL-MAP Length		0 to 2037 byte: The calculation value is displayed when UL-MAP Type = UL-MAP or Compressed UL-MAP The length of payload data for UL-MAP can be set in other cases	
UCD Count		0 to 255: Can be set when UL-MAP Type = UL-MAP or Compressed UL-MAP	
Uplink Allocation Start Time		Display only: Set at Common	
Zone# UL-MAP IE#			
CID		0 to 65535	
UIUC (Uplink Interval Usage Code)		1 to 10	
UL-Burst Duration		Display only: Set at UL-Burst	
Repetition Coding Indication		Display only: Set at UL-Burst	

Tree	Items	Setting Range	
DCD	Data Status	Enable, Disable	
	DCD Offset	0 to (Number of Frames-1)	
	DCD Interval	0 to Number of Frames	
	DCD Length	0 to 2037 (without DCD Data Type = TLV) Display only (when DCD Data Type = TLV)	
	DCD Data Type	16bit repeat, PN9fix, PN15fix, S_QPSK, S_16QAM, S_64QAM, User File, TLV	
	Configuration Change Count	0 to 255	
	TLV encoded information		
	Frequency	0 to 6000000 kHz	
	Base Station ID	000000000000 to FFFFFFFF	
	MAC version	1 to 6	
	BS EIRP	-32768 to +32767	
	TTG	Display only	
	RTG	Display only	
	EIRxP_IR_MAX	-32768 to +32767	
	HO Type Support	HO, MDHO, FBSS HO	
	Paging Group ID	0000 to FFFF	
	Trigger Type	0 to 3	
	Trigger Function	0 to 6	
	Trigger Action	1 to 3	
	Trigger Value	00 to FF	
	Trigger averaging Duration	0 to 255	
	BS Restart Count	00 to FF	
	Default RSSI and CINR averaging parameter	00 to FF	
	DL AMC Allocated Physical Bands Bitmap	Display only	
	Hysteresis margin	00 to FF	
	Time to trigger duration	00 to FF	
	DL-Burst Profile (DIUC = 0 to 12)		
	FEC Type	Display only	
	UCD	Data Status	Enable, Disable
		UCD Offset	0 to (Number of Frames-1)
		UCD Interval	0 to Number of Frames
		UCD Length	0 to 2037 (without UCD Data Type = TLV) Display only (when UCD Data Type = TLV)
		UCD Data Type	16bit repeat, PN9fix, PN15fix, S_QPSK, S_16QAM, S_64QAM, User File, TLV
Configuration Change Count		0 to 255	
Ranging Backoff Start		0 to 255	
Ranging Backoff End		0 to 255	
Request Backoff Start		0 to 255	
Request Backoff End		0 to 255	
TLV encoded information			
Frequency		0 to 6000000 kHz	
Contention-based Reservation Timeout		00 to FF	
Start of Ranging Coded Group		00 to FF	
Band AMC Allocation Threshold		00 to FF	
Band AMC Release Threshold		00 to FF	
Band AMC Allocation Timer		00 to FF	
Band AMC Release Timer		00 to FF	
Band AMC Status Reporting Max Period		00 to FF	
Band AMC Retry Timer		00 to FF	
Normalized C/N Override-2		0000000000000000 to FFFFFFFF	
Use CQICH Indication Flag		00 to FF	
Handover Ranging Code		00 to FF	
Initial Ranging Codes		00 to FF	
Initial Ranging Interval		00 to FF	
Tx Power Report		0000 to FFFF	
Normalized C/N for channel Sounding		00 to FF	
Initial Ranging Backoff Start		00 to FF	
Initial Ranging Backoff End		00 to FF	
Bandwidth request Backoff Start		00 to FF	
Bandwidth request Backoff End		00 to FF	
Permutation Base		00 to FF	

Tree	Items	Setting Range	
UCD (Cont'd)	UL Allocated Subchannels Bitmap	Display only	
	HARQ Ack Delay for DL burst	00 to FF	
	UL AMC Allocated Physical Bands Bitmap	000000000000 to FFFFFFFF	
	Size of CQICH-ID field	00 to FF	
	Band-AMC entry average CINR	00 to FF	
	HO ranging start	00 to FF	
	HO ranging end	00 to FF	
	Periodic Ranging Codes	00 to FF	
	Bandwidth Request Codes	00 to FF	
	Periodic Ranging Backoff Start	00 to FF	
	Periodic Ranging Backoff End	00 to FF	
	CQICH Band AMC Transition Delay	00 to FF	
	UL-Burst Profile (UIUC = 1 to 10)		
	FEC Type	Display only	
	Ranging Data ratio	00 to FF	
	MAC PDU 0 to 31	Data Status	Enable, Disable
		MAC PDU Length	Display only
Payload Data Length		0 to 2041 byte (when CI = No CRC) 0 to 2037 byte (when CI = With CRC) 0 to 2047 byte (when CI = Without Header & CRC)	
CID (Connection Identifier)		0 to 65535	
CI		With CRC, No CRC, Without Header & CRC	
CRC Error Insertion		Correct, Error	
Payload Type		16bit repeat, PN9fix, PN15fix, S_QPSK, S_16QAM, S_64QAM, User File	
Payload Type Repeat Data		0000 to FFFF: Can be set when Payload Type = 16bit repeat	
Payload Type User File		User File selected: Can be set when Payload Type = User File	
MAP-Burst	Data Status	Enable, Disable	
	OFDMA Symbol Offset	<ul style="list-style-type: none"> • 0 to 254 symbol without Preamble at Zone#0 (Select by even symbol) • 1 to 255 symbol with Preamble at Zone#0 (Select by odd symbol) • (OFDMA Symbol Offset at Zone) to 255 symbol when PUSC Zone from Zone#1 to #7 • (OFDMA Symbol Offset at Zone) to 255 symbol when PUSC (all SC) Zone • (OFDMA Symbol Offset at Zone) to 255 symbol when FUSC Zone • (OFDMA Symbol Offset at Zone) to 255 symbol when AMC (6 × 1) Zone • (OFDMA Symbol Offset at Zone) to 255 symbol when AMC (3 × 2) Zone • (OFDMA Symbol Offset at Zone) to 255 symbol when AMC (2 × 3) Zone • (OFDMA Symbol Offset at Zone) to 255 symbol when AMC (1 × 6) Zone 	
	OFDMA Subchannel Offset	0 to (number of Subchannel at Zone)	
	Length	1 to 255 slot	
	Repetition Coding Indication	No Repetition, 2, 4, 6	
	FEC Code Type and Modulation Type	QPSK (CC) 1/2, QPSK (CC) 3/4, 16QAM (CC) 1/2, 16QAM (CC) 3/4, 64QAM (CC) 1/2, 64QAM (CC) 2/3, 64QAM (CC) 3/4, QPSK (CTC) 1/2, QPSK (CTC) 3/4, 16QAM (CTC) 1/2, 16QAM (CTC) 3/4, 64QAM (CTC) 1/2, 64QAM (CTC) 2/3, 64QAM (CTC) 3/4, 64QAM (CTC) 5/6, QPSK (No Ch Coding), 16QAM (No Ch Coding), 64QAM (No Ch Coding)	
	MAP-Burst Data Type	16bit repeat, PN9fix, PN15fix, S_QPSK, S_16QAM, S_64QAM, MAC PDU, User File	
	MAP-Burst Data Type Repeat Data	0000 to FFFF: Can be set when MAP-Burst Data Type = 16bit repeat	
	MAP-Burst Data Type User File	User File selected: Can be set when MAP-Burst Data Type = User File	
	MAC PDU Number	0 to 32: Display when MAP-Burst Data Type = MAC PDU	
	DL-HARQ Burst	Data Status	Enable, Disable
RCID_Type		Normal CID, RCID11, RCID7, RCID3	
OFDMA Symbol Offset		<ul style="list-style-type: none"> • 0 to 254 symbol without Preamble at Zone#0 (Can be selected by even symbol) • 1 to 255 symbol with Preamble at Zone#0 (Can be selected by odd symbol) • (OFDMA Symbol Offset at Zone) to 255 symbol when PUSC Zone from Zone#1 to #7 • (OFDMA Symbol Offset at Zone) to 255 symbol when PUSC (all SC) Zone • (OFDMA Symbol Offset at Zone) to 255 symbol when FUSC Zone • (OFDMA Symbol Offset at Zone) to 255 symbol when AMC (6 × 1) Zone • (OFDMA Symbol Offset at Zone) to 255 symbol when AMC (3 × 2) Zone • (OFDMA Symbol Offset at Zone) to 255 symbol when AMC (2 × 3) Zone • (OFDMA Symbol Offset at Zone) to 255 symbol when AMC (1 × 6) Zone 	
OFDMA Subchannel Offset		0 to (Number of Subchannel at Zone)	
Boosting		-12, -9, -6, -3, 0, +3, +6, +9 dB	
Rectangular Sub-Burst Indicator		0, 1	

Tree	Items	Setting Range
DL-HARQ Burst (Cont'd)	No. OFDMA Symbols	2 to 126 symbol (when PUSC)
		2 to 126 symbol (when PUSC (all SC))
		1 to 127 symbol (when FUSC)
		1 to 127 symbol (when AMC (6 × 1))
		2 to 126 symbol (when AMC (3 × 2))
		3 to 126 symbol (when AMC (2 × 3))
	No. Subchannels	6 to 126 symbol (when AMC (1 × 6))
	No. Subchannels	1 to 127
	Mode	Chase HARQ, MIMO Chase HARQ
	N sub Burst	1 to 16
	N ACK Channel	0 to 15
	Inclusion MAP	Normal, SUB-DL-UL-MAP#n (n = 0 to 2)
Sub-Burst	Data Status	Enable, Disable
	CID	0 to 65535
	Sub-Burst Duration	1 to 1023
	Sub-Burst DIUC Indication	0, 1
	Repetition Coding Indication	No repetition, 2, 4, 6
	FEC Code Type and Modulation Type	QPSK (CC) 1/2, QPSK (CC) 3/4, 16QAM (CC) 1/2, 16QAM (CC) 3/4, 64QAM (CC) 1/2, 64QAM (CC) 2/3, 64QAM (CC) 3/4, QPSK (CTC) 1/2, QPSK (CTC) 3/4, 16QAM (CTC) 1/2, 16QAM (CTC) 3/4, 64QAM (CTC) 1/2, 64QAM (CTC) 2/3, 64QAM (CTC) 3/4, 64QAM (CTC) 5/6, QPSK (No Ch Coding), 16QAM (No Ch Coding), 64QAM (No Ch Coding)
	Sub-Burst Data Type	16bit repeat, PN9fix, PN15fix, S_QPSK, S_16QAM, S_64QAM, MAC PDU, User File
	Sub-Burst Data Type Repeat Data	0x0000 to 0xFFFF
	Sub-Burst Data Type User File	User File selected when Sub-Burst Data Type = User File
	MAC PDU Number	0 to 32
	MU Indicator	0, 1
	Dedicated MIMO DL Control Indicator	0, 1
	Matrix Indicator	Matrix A, Matrix B
	CRC Error Insertion	Correct, Error
	ACID	0 to 15
	AI_SN	0, 1
	ACK disable	0, 1
	Dedicated DL Control Indicator	00, 01, 10, 11
	Duration (d)	0 to 15
	Allocation Index	0 to 63
	Period (p)	0 to 7
Frame Offset	0 to 7	
Dedicated DL Control IE	0, 1	
No. SDMA layers	1 to 4	

PHY/MAC Parameter (Uplink) Setting Range

Tree	Items	Setting Range
Uplink	Data Status	Enable, Disable
Zone 0 to 7	Data Status	Enable, Disable
	Permutation	PUSC, PUSC (without SC rotation), AMC (6 × 1), AMC (3 × 2), AMC (2 × 3), AMC (1 × 6)
	Pilot Position	Hopping, Center
	STC/MIMO	Display only
	OFDMA Symbol Offset	0 to 255 symbol (Zone#0 = 0)
	No. OFDMA Symbols	3 to 255 symbol (when PUSC)
		3 to 255 symbol (when PUSC (without SC rotation))
		1 to 255 symbol (when AMC (6 × 1))
		2 to 254 symbol (when AMC (3 × 2))
		3 to 255 symbol (when AMC (2 × 3))
UL-PermBase	6 to 252 symbol (AMC (1 × 6))	
UL-Burst Number	0 to 69	
	UL-Burst Number	1 to 16

Tree	Items	Setting Range	
UL-Burst 0 to 15	Data Status	Enable, Disable	
	OFDMA Symbol Offset	<ul style="list-style-type: none"> When PUSC Zone (OFDMA Symbol Offset at Zone) to (OFDMA Symbol Offset at Zone + No. OFDMA Symbols at Zone) symbol When PUSC (without SC rotation) Zone (OFDMA Symbol Offset at Zone) to (OFDMA Symbol Offset at Zone + No. OFDMA Symbols at Zone) symbol When AMC (6 × 1) Zone (OFDMA Symbol Offset at Zone) to (OFDMA Symbol Offset at Zone + No. OFDMA Symbols at Zone) symbol When AMC (3 × 2) Zone (OFDMA Symbol Offset at Zone) to (OFDMA Symbol Offset at Zone + No. OFDMA Symbols at Zone) symbol When AMC (2 × 3) Zone (OFDMA Symbol Offset at Zone) to (OFDMA Symbol Offset at Zone + No. OFDMA Symbols at Zone) symbol When AMC (1 × 6) Zone (OFDMA Symbol Offset at Zone) to (OFDMA Symbol Offset at Zone + Zone No. OFDMA Symbols) symbol 	
	OFDMA Subchannel Offset	Subchannel - 1 at 0 to Zone	
	UL Burst Duration	3 to 3069 symbol (when PUSC) 3 to 3069 symbol (when PUSC (without SC rotation)) 1 to 1023 symbol (when AMC (6 × 1)) 2 to 2046 symbol (when AMC (3 × 2)) 3 to 3069 symbol (when AMC (2 × 3)) 6 to 6138 symbol (when AMC (1 × 6))	
	Burst Power Offset	-10.00 to +10.00 dB	
	Pilot Pattern	Normal, Pattern A, Pattern B	
	Repetition Coding Indication	No repetition, 2, 4, 6: Can be set when FEC Code Type and Modulation Type = QPSK (CC) 1/2, QPSK (CC) 3/4, QPSK (CTC) 1/2, QPSK (CTC) 3/4, QPSK (No Ch Coding); no repetition fixed in other cases	
	FEC Code Type and Modulation Type	QPSK (CC) 1/2, QPSK (CC) 3/4, 16QAM (CC) 1/2, 16QAM (CC) 3/4, 64QAM (CC) 1/2, 64QAM (CC) 2/3, 64QAM (CC) 3/4, QPSK (CTC) 1/2, QPSK (CTC) 3/4, 16QAM (CTC) 1/2, 16QAM (CTC) 3/4, 64QAM (CTC) 1/2, 64QAM (CTC) 2/3, 64QAM (CTC) 3/4, 64QAM (CTC) 5/6, QPSK (No Ch Coding), 16QAM (No Ch Coding), 64QAM (No Ch Coding)	
	Inclusion MAP	Normal, SUB-DL-UL-MAP#n (n = 0 to 2)	
	UL-Burst Data Type	16 bit repeat, PN9fix, PN15fix, S_QPSK, S_16QAM, S_64QAM, MAC PDU, User File	
	UL-Burst Data Type Repeat Data	0000 to FFFF: Can be set when UL-Burst Data Type = 16bit repeat	
	UL-Burst Data Type User File	User File selected: Can be set when UL-Burst Data Type = User File	
	MAC PDU Number	0 to 32	
	MAC PDU 0 to 31	<See MAC PDU on Downlink>	
UL-HARQ Burst	Data Status	Enable, Disable	
	RCID_Type	Normal CID, RCID11, RCID7, RCID3	
	OFDMA Symbol Offset	<ul style="list-style-type: none"> When PUSC Zone (OFDMA Symbol Offset at Zone) to (OFDMA Symbol Offset at Zone + No. OFDMA Symbols at Zone) symbol When PUSC (without SC rotation) Zone (OFDMA Symbol Offset at Zone) to (OFDMA Symbol Offset at Zone + No. OFDMA Symbols at Zone) symbol When AMC (6 × 1) Zone (OFDMA Symbol Offset at Zone) to (OFDMA Symbol Offset at Zone + No. OFDMA Symbols at Zone) symbol When AMC (3 × 2) Zone (OFDMA Symbol Offset at Zone) to (OFDMA Symbol Offset at Zone + No. OFDMA Symbols at Zone) symbol When AMC (2 × 3) Zone (OFDMA Symbol Offset at Zone) to (OFDMA Symbol Offset at Zone + No. OFDMA Symbols at Zone) symbol When AMC (1 × 6) Zone (OFDMA Symbol Offset at Zone) to (OFDMA Symbol Offset at Zone + No. OFDMA Symbols at Zone) symbol 	
	OFDMA Subchannel Offset	0 to (Subchannel number-1 at Zone)	
	Mode	Chase HARQ (Display only)	
	Allocation Start Indication	0, 1	
	N sub Burst	1 to 16	
	Inclusion MAP	Normal, SUB-DL-UL-MAP#n (n = 0 to 2)	
	Sub-Burst	Data Status	Enable, Disable
		CID	0 to 65535
FEC Code Type and Modulation Type		QPSK (CC) 1/2, QPSK (CC) 3/4, 16QAM (CC) 1/2, 16QAM (CC) 3/4, 64QAM (CC) 1/2, 64QAM (CC) 2/3, 64QAM (CC) 3/4, QPSK (CTC) 1/2, QPSK (CTC) 3/4, 16QAM (CTC) 1/2, 16QAM (CTC) 3/4, 64QAM (CTC) 1/2, 64QAM (CTC) 2/3, 64QAM (CTC) 3/4, 64QAM (CTC) 5/6, QPSK (No Ch Coding), 16QAM (No Ch Coding), 64QAM (No Ch Coding)	
Repetition Coding Indication		No repetition, 2, 4, 6	
Sub-Burst Duration		1 to 1023 (slot)	
Sub-Burst Data Type		16bit repeat, PN9fix, PN15fix, S_QPSK, S_16QAM, S_64QAM, MAC PDU, User File	
Sub-Burst Data Type Repeat Data		0x0000 to 0xFFFF	
Sub-Burst Data Type User File		Display only when Sub-Burst Data Type = User File	
MAC PDU Number		0 to 32	
CRC Error Insertion		Correct, Error	
Dedicated UL Control Indicator	0, 1		
SDMA Control Info bit	0, 1		

Tree	Items	Setting Range
Sub-Burst (Cont'd)	Num SDMA layers	0 to 3
	Pilot Pattern	Pattern A, Pattern B, Pattern C, Pattern D
	ACID	0 to 15
	AI_SN	0, 1
	ACK disable	0, 1
Initial/ Handover Ranging Region	Data Status	Enable, Disable
	OFDMA Symbol Offset	<ul style="list-style-type: none"> When PUSC Zone, (OFDMA Symbol Offset at Zone) to 255 symbol When PUSC (without SC rotation) Zone, (OFDMA Symbol Offset at Zone) to 255 symbol When AMC (6 × 1) Zone, (OFDMA Symbol Offset at Zone) to 255 symbol When AMC (3 × 2) Zone, (OFDMA Symbol Offset at Zone) to 255 symbol When AMC (2 × 3) Zone, (OFDMA Symbol Offset at Zone) to 255 symbol When AMC (1 × 6) Zone, (OFDMA Symbol Offset at Zone) to 255 symbol
	OFDMA Subchannel Offset	0 to 126 (when PUSC, PUSC (without SC rotation)) 0 to 120 (without PUSC, PUSC (without SC rotation))
	No. OFDMA Symbols	3 to 126 symbol (when PUSC) 3 to 126 symbol (when PUSC (without SC rotation)) 1 to 127 symbol (when AMC (6 × 1)) 2 to 126 symbol (when AMC (3 × 2)) 3 to 126 symbol (when AMC (2 × 3)) 6 to 126 symbol (when AMC (1 × 6))
	No. Subchannels	6 to 126 (when PUSC, PUSC (without SC rotation)) 8 to 120 (without PUSC, PUSC (without SC rotation))
	Initial/Handover Ranging Symbols	2, 4
	Initial/Handover Ranging Burst Number	1 to 16
	Ranging Region Combination	Non, Combine
	BW Request/Periodic Ranging Offset	0 to No. OFDMA Symbols at Initial/Handover Ranging Region
	BW Request/Periodic Ranging Symbols	1, 3
	BW Request/Periodic Ranging Burst Number	0 to 16
	Initial/ Handover Ranging Burst	Data Status
OFDMA Symbol Offset		<ul style="list-style-type: none"> When Initial/Handover Ranging Symbols = 2, 0 to 254 symbol setting resolution = 2 When Initial/Handover Ranging Symbols = 4, 0 to 252 symbol
OFDMA Subchannel Offset		0 to 126 (when PUSC, PUSC (without SC rotation)) 0 to 120 (without PUSC, PUSC (without SC rotation))
No. OFDMA Symbols		Display only
No. Subchannels		Display only
Ranging Power Offset		-10.00 to +10.00 dB
Ranging Code Number		0 to 255
BW Request/ Periodic Ranging Region	Data Status	Enable, Disable
	OFDMA Symbol Offset	<ul style="list-style-type: none"> When PUSC Zone, (OFDMA Symbol Offset at Zone) to 255 symbol When PUSC (without SC rotation) Zone, (OFDMA Symbol Offset at Zone) to 255 symbol When AMC (6 × 1) Zone, (OFDMA Symbol Offset at Zone) to 255 symbol When AMC (3 × 2) Zone, (OFDMA Symbol Offset at Zone) to 255 symbol When AMC (2 × 3) Zone, (OFDMA Symbol Offset at Zone) to 255 symbol When AMC (1 × 6) Zone, (OFDMA Symbol Offset at Zone) to 255 symbol
	OFDMA Subchannel Offset	0 to 126 (when PUSC, PUSC (without SC rotation)) 0 to 120 (without PUSC, PUSC (without SC rotation))
	No. OFDMA Symbols	3 to 126 symbol (when PUSC) 3 to 126 symbol (when PUSC (without SC rotation)) 1 to 127 symbol (when AMC (6 × 1)) 2 to 126 symbol (when AMC (3 × 2)) 3 to 126 symbol (when AMC (2 × 3)) 6 to 126 symbol (when AMC (1 × 6))
	No. Subchannels	6 to 126 (when PUSC, PUSC (without SC rotation)) 8 to 120 (without PUSC, PUSC (without SC rotation))
	BW Request/Periodic Ranging Symbols	1, 3
	BW Request/Periodic Ranging Burst Number	1 to 16
	BW Request/ Periodic Ranging Burst	Data Status
OFDMA Symbol Offset		0 to 255
OFDMA Subchannel Offset		0 to 126 (when PUSC, PUSC (without SC rotation)) 0 to 120 (without PUSC, PUSC (without SC rotation))
No. OFDMA Symbols		Display only
No. Subchannels		Display only
Ranging Power Offset		-10.00 to +10.00 dB
Ranging Code Number		0 to 255

Tree	Items	Setting Range	
Fast-Feedback Region	Data Status	Enable, Disable	
	OFDMA Symbol Offset	OFDMA Symbol Offset at Zone to 255 symbol	
	OFDMA Subchannel Offset	0 to 127	
	No. OFDMA Symbols	3 to 126	
	No. Subchannels	1 to 127	
	Fast-Feedback Type	Display only	
	Fast-Feedback Burst Number	1 to 32	
	Fast-Feedback Burst	Data Status	Enable, Disable
		OFDMA Symbol Offset	0 to 255
		OFDMA Subchannel Offset	0 to 127
		No. OFDMA Symbols	Display only
		No. Subchannels	Display only
		Ranging Power Offset	-10.00 to +10.00 dB
		Payload	000000 to 111111
UL-ACK Region	Data Status	Enable, Disable	
	OFDMA Symbol Offset	(OFDMA Symbol Offset at Zone) to 255 symbol	
	OFDMA Subchannel Offset	0 to 127	
	No. OFDMA Symbols	3 to 126 symbol	
	No. Subchannels	1 to 127	
	UL-ACK Burst Number	1 to 32	
	UL-ACK Burst	Data Status	Enable, Disable
OFDMA Symbol Offset		0 to 255 symbol	
OFDMA Subchannel Offset		0 to 127	
No. OFDMA Symbols		Display only	
No. Subchannels		Display only	
Occupied half subchannel		even, odd	
UL-ACK Burst Power Offset		-10.00 to +10.00 dB	
Payload		ACK, NACK	
Sounding Zone	Data Status	Enable, Disable	
	OFDMA Symbol Offset	0 to 255 symbol	
	No. OFDMA Symbols	1 to 8	
	Sounding Type	Type A (Display only)	
	Send Sounding Report Flag	0, 1	
	Sounding Relevance Flag	0, 1	
	Sounding Relevance	0, 1	
	Include additional feedback	No additional feedback, Channel coefficients, Received pilot coefficients, Feedback message	
	Shift Value	0 to 127	
	Sounding Symbol	Data Status	Enable, Disable
Separability Type		All subcarriers, Decimated subcarriers	
Max. Cyclic Shift Index P		4, 8, 16, 32, 9, 18	
Decimated Value D		2, 4, 8, 16, 32, 64, 128, 5	
Decimated offset randomization		No randomization, Pseudo-randomly	
Sounding Symbol Index		1 to 8	
Number of CIDs		1 to 128	
CID		Data Status	Enable, Disable
	Shorted Basic CID	0 to 4095	
	Power Assignment Method	Equal power, Per subcarrier power limit, Total power limit	
	Power Boost	No power boost, Power boost	
	Multi-Antenna Flag	First antenna only, All antennas	
	Allocation Mode	Normal, Band	
	Start Frequency Band	<ul style="list-style-type: none"> • 0 to 95 when FFT Size = 2048 • 0 to 47 when FFT Size = 1024 • 0 to 23 when FFT Size = 512 • 0 to 5 when FFT Size = 128 	
	No. Frequency Bands	<ul style="list-style-type: none"> • 1 to 96 when FFT Size = 2048 • 1 to 48 when FFT Size = 1024 • 1 to 24 when FFT Size = 512 • 1 to 6 when FFT Size = 128 	
	Band Bitmap	<ul style="list-style-type: none"> • 0 to FFF when FFT Size = 2048, 1024, 512 • 0 to 7 when FFT Size = 128 	
	Sounding Relevance	0, 1	
	Cyclic time shift index m	0 to (Max Cyclic Shift Index P-1 at Sounding Symbol that CID belongs to)	
	Decimated Offset d	0 to (Decimated Value D-1 at Sounding Symbol that CID belongs to)	
	Use same symbol for additional feedback	0, 1	
	Periodicity	Single, 1, 2, 4	

LTE IQproducer MX269908A/LTE-Advanced FDD Option MX269908A-001

Optional

MS269xA

MS2830A

The LTE IQproducer MX269908A is PC application software with a GUI for generating waveform patterns in compliance with the LTE FDD specifications in the 3GPP TS 36.211, TS 36.212, and TS 36.213 standards.

Generates test model waveform patterns used for LTE base station Tx tests and FRC (Fixed Reference Channel) used for Rx tests.

LTE IQproducer supports two setting screens: "Easy Setup Screen" and "Normal Setup Screen".

The LTE-Advanced FDD option MX269908A-001 supports simple generation of carrier aggregation signals added* by 3GPP Rel. 10. Additionally, clustered SC-FDMA signals can be generated at Uplink.

*: MBSFN reference signals, UE-specific reference signals, Positioning reference signals, CSI reference signals, and Physical Multicast Channel are not supported.

Easy Setup Screen

Waveform patterns can be generated easily because the main parameters are restricted to the Easy Setup screen. Use "Normal Setup function" for detailed parameter settings.

Channels Generated by MX269908A

Downlink

- Cell-specific Reference Signal
- Primary Synchronization Signal
- Secondary Synchronization Signal
- PBCH (Physical Broadcast Channel)
- PCFICH (Physical Control Format Indicator Channel)
- PDCCH (Physical Downlink Control Channel)
- PDSCH (Physical Downlink Shared Channel)
- PHICH (Physical Hybrid-ARQ Indicator Channel)

Uplink

- PUCCH (Physical Uplink Control Channel)
- PUSCH (Physical Uplink Shared Channel)
- Demodulation Reference Signal for PUCCH/PUSCH
- Sounding Reference Signal
- Random Access Preamble

The image shows the 'Easy Setup (LTE FDD)' window with several callout boxes pointing to specific features:

- E-UTRA Test Models by Signal Type:** A window showing options for E-TM1.1, E-TM1.2, E-TM2, E-TM3.1, E-TM3.2, and E-TM3.3.
- System:** A window with buttons for 'LTE' and 'LTE-Advanced'.
- Test Type:** A window with buttons for 'BS Test' and 'FRC(UL)'. The 'FRC(UL)' button is selected in the main window.
- Bandwidth:** A window with buttons for 1.4MHz, 3MHz, 5MHz, 10MHz, 15MHz, and 20MHz. '5MHz' is selected in the main window.
- Filter:** A window with buttons for 'None' and 'Ideal'. 'Ideal' is selected in the main window.
- FRC (UL) by Signal Type:** A window showing a table of parameters for FRC(UL) signals.
- Data:** A window for 'UL-SCH' with 'Transport Block Size' set to 600 bit and 'Data Type' set to 'PN9fx'. An 'OK' button is at the bottom.
- Modulation:** A window with buttons for 'QPSK', '16QAM', and '64QAM'. 'QPSK' is selected in the main window.

The main 'Easy Setup (LTE FDD)' window contains the following fields and controls:

- System:** LTE (selected)
- Test Type:** BS Test/FRC(UL) (selected)
- Common:** FRC(UL) A1-1, Bandwidth 5MHz, Cell ID 0, Roll Off Length 0, Tx Filter Ideal
- PUSCH:** Start Number of RB 0, nRNTI 0 hex, Modulation QPSK, UL-SCH
- DMRS for PUSCH:** Group Hopping Off, Sequence Hopping Off, Delta ss 0, n(1) DMRS 0, n(2) DMRS 0
- Sounding RS:** SRS Off, SRS Subframe Configuration 0
- Pattern Setting:** Package LTE_FDD, Export File Name FRC_A1-1_05M
- Buttons:** Calculation, Exit

Easy Setup Screen (Example: FRC_UL)

Normal Setup Screen

Detailed parameters are set at the Normal Setup screen to generate waveform patterns.

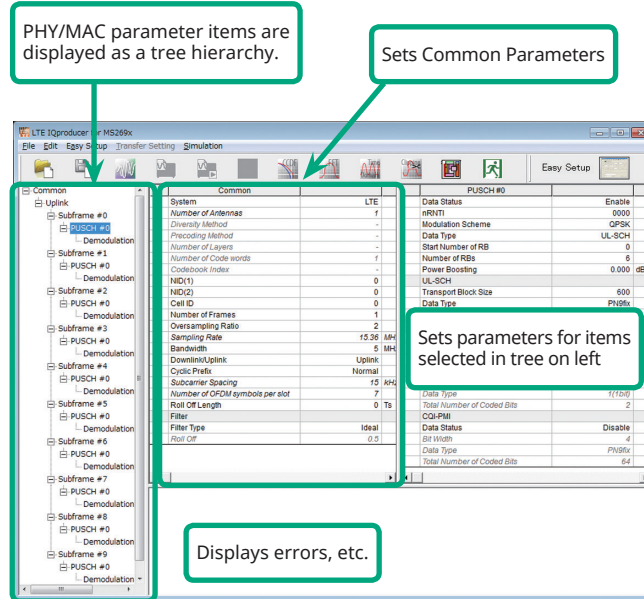

LTE IQproducer Setting Screen/Normal Setup Screen

Easy Setup Menu

3GPP-defined test conditions can be selected from the Easy Setup menu tree to set values for the Normal Setup screen parameters.

BS Test/E-UTRA Test Models

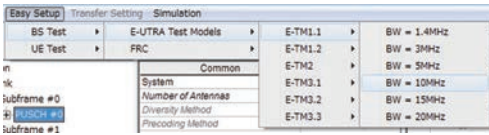

UE Test/RMC (DL)/FRC

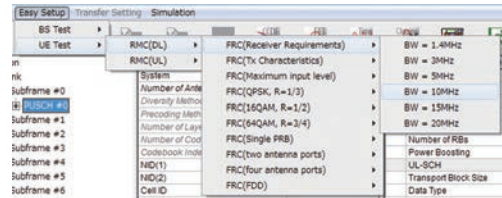

BS Test/FRC

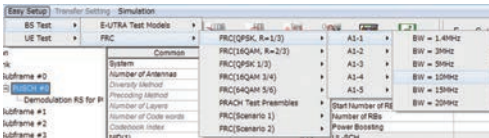

UE Test/RMC (UL)

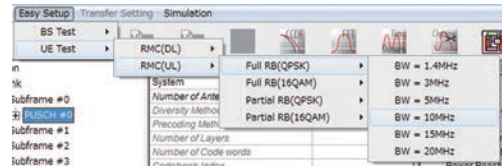

Visual Check on Frame Structure Screen

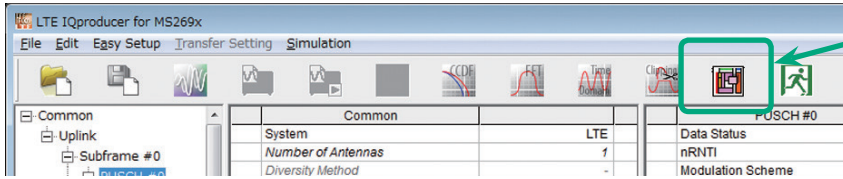

Displays Frame Structure screen for confirming channel allocation status and power of each OFDM Symbol

Power graph show/hide button
 Full Scale button
 Antenna Port select button

Display Resource Element allocation graphically with each channel color-coded.
 Y-axis: Frequency (Resource Block units)
 X-axis: Time (OFDM Symbol units)

Display power relative levels of OFDM Symbols with maximum power of 0 dB.
 Y-axis: OFDM Symbol Power
 X-axis: Time (OFDM Symbol units)

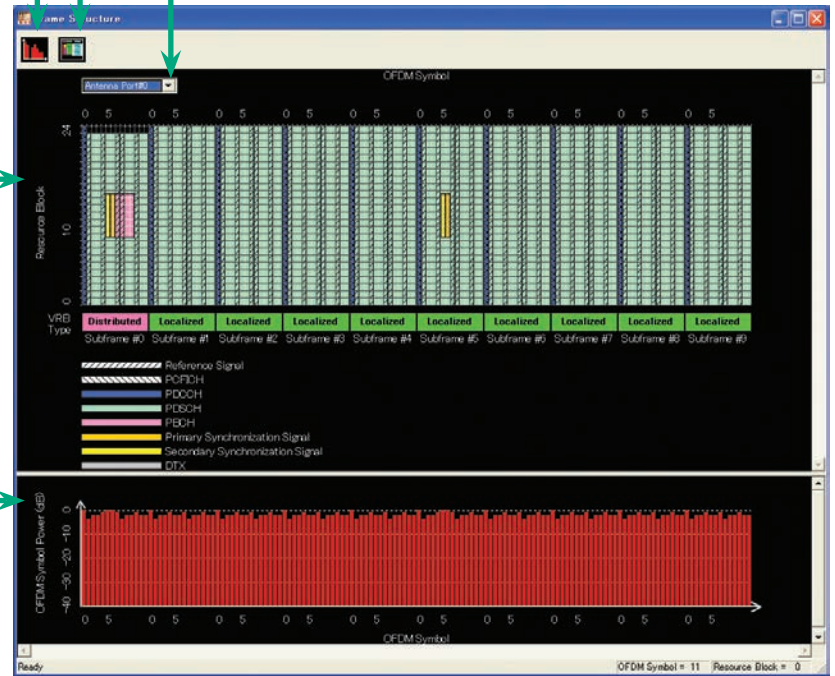

Frame Structure Screen (LTE)

LTE-Advanced FDD Option MX269908A-001

Adding the LTE-Advanced FDD Option MX269908A-001 to set LTE-Advanced system parameters supports generation of carrier aggregation signals added* by 3GPP Rel. 10.

Additionally, clustered SC-FDMA signals can be generated at Uplink.

*: MBSFN reference signals, UE-specific reference signals, Positioning reference signals, CSI reference signals, and Physical Multicast Channel are not supported.

LTE-Advanced Setting Parameters

Carrier Aggregation Mode

Intra-band

Component Carrier: #0 to #4

Inter-band

Band #0, #1

Component Carrier: #0 to #4

Easy Setup Screen

Waveform patterns can be generated easily by setting the band matching the carrier aggregation mode and component carrier because the main parameters are restricted to the Easy Setup screen.

Use the "Normal Setup Function" for detailed parameter settings.

The screenshot shows the 'Easy Setup (LTE FDD)' window. Callouts point to the following elements:

- Carrier Aggregation Mode:** A dialog box with 'Intra-band' and 'Inter-band' buttons.
- System:** A dialog box with 'LTE' and 'LTE-Advanced' buttons.
- Test Type:** A dialog box with 'E-UTRA Test Models' and 'FRC(UL)' buttons.
- Component Carrier Setup:** A list of parameters: Intra-band, Component Carrier: #0 to #4, Inter-band, Band #0, #1, Component Carrier: #0 to #4. Below it, a list of 'Setup Item' parameters: Status, Bandwidth, Cell ID, Gain, Frequency Offset, Phase, Delay.
- Main Table:** A table with columns: Component Carrier, Status, Bandwidth (MHz), Cell ID, Gain (dB), Freq Offset (kHz), Phase (deg), Delay (Ts), and BS Test/FRC(UL). The table contains 5 rows of data for component carriers 0 through 4.

Component Carrier	Status	Bandwidth (MHz)	Cell ID	Gain (dB)	Freq Offset (kHz)	Phase (deg)	Delay (Ts)	BS Test/FRC(UL)
0	<input checked="" type="checkbox"/>	5	1	0.00	+102000	0	0	A1-1
1	<input checked="" type="checkbox"/>	5	2	0.00	-51000	0	0	A1-1
2	<input checked="" type="checkbox"/>	5	3	0.00	00000	0	0	A1-1
3	<input checked="" type="checkbox"/>	5	4	0.00	+51000	0	0	A1-1
4	<input checked="" type="checkbox"/>	5	5	0.00	+102000	0	0	A1-1

FRC (UL) Setup Screen

The screenshot shows the 'BS Test/FRC(UL)' dialog box. Fields include:

- FRC(UL): A1-1, Bandwidth: 5MHz, Cell ID: 0, Roll Off Length: 0, Ts Filter: Ideal
- PUSCH: Start Number Of RB: 0, nRNTI: 0000, hex, Modulation: QPSK, UL-SCH
- DMRS for PUSCH: Group Hopping: OFF, Sequence Hopping: OFF, Delta ss: 0, n(1),DMRS: 0, n(2),DMRS: 0
- Sounding RS: SRS: OFF, SRS Subframe Configuration: 0

E-UTRA Test Models Setup Screen

The screenshot shows the 'BS Test/E-UTRA Test Models' dialog box. Fields include:

- E-UTRA Test Models: E-TMR.1, Bandwidth: 5MHz, Cell ID: 1, Roll Off Length: 0, Ts Filter: Ideal

LTE-Advanced Easy Setup Screen (Example: FRC (UL))

Normal Setup Screen

Detailed parameters are set at the Normal Setup screen to generate waveform patterns.

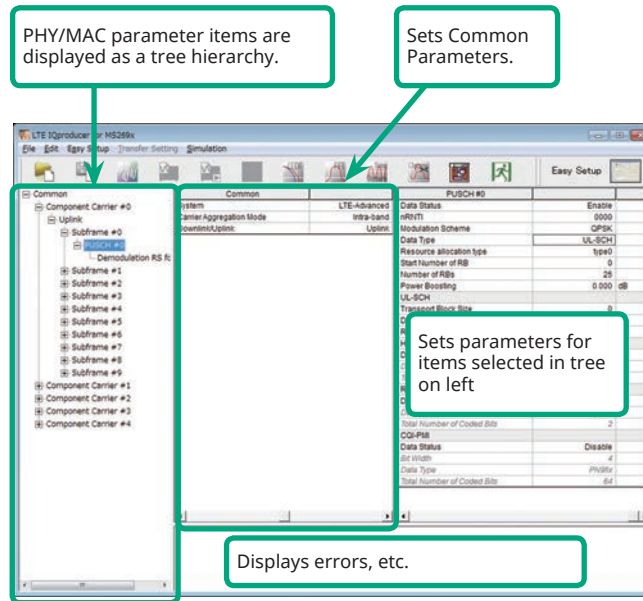

LTE-Advanced Setting Screen/Normal Setup Screen

Easy Setup Menu

3GPP-defined test conditions can be selected from the Easy Setup menu tree to set values for the Normal Setup screen parameters.

Example: FRC setup

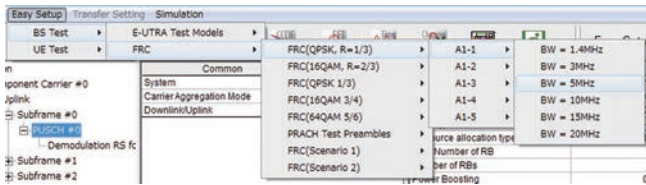

Simple operation by selecting target signals and component carriers as batch

Select Component Carrier Screen

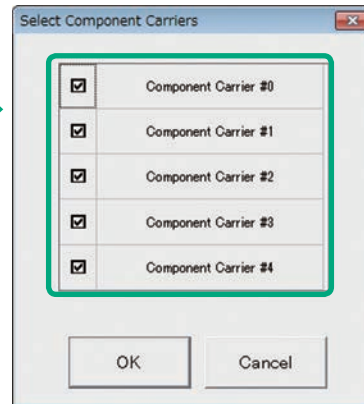

Example of Vector Signal Generator series LTE-Advanced Carrier Aggregation Function

Carrier Aggregation Mode	Vector Signal Generator Series		Vector Signal Generator Option for Signal Analyzer	
	MG3710A*1	MG3700A*1	MS2690A series Option 020	MS2830A Option 020/021
Intra-band contiguous Carrier Aggregation, Intra-band non-contiguous Carrier Aggregation	✓ (1 unit)	✓ (1 unit)	✓ (1 unit)	✓ (1 unit)
Inter-band non-contiguous Carrier Aggregation	✓ (2RF 1 unit*2, or 1RF 2 units)	✓ (2 units)	✓ (2 units)	✓ (2 units)

*1: LTE IQproducer MX370108A and LTE-Advanced FDD Option MX370108A-001 installed.

*2: MG3710A-062 (2.7 GHz)/064 (4 GHz)/066 (6 GHz) 2ndRF Option installed.

Visual Check on Frame Structure Screen

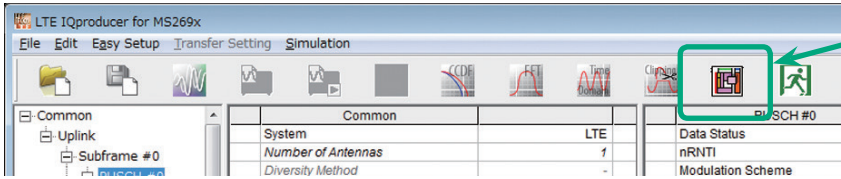

Displays Frame Structure screen for confirming channel allocation status and power of each OFDM Symbol

Power graph show/hide button

Full Scale button

Component Carrier select button

Band select button

Antenna Port select button

Display Resource Element allocation graphically with each channel color-coded.
Y-axis: Frequency (Resource Block units)
X-axis: Time (OFDM Symbol units)

Display power relative levels of OFDM Symbols with maximum power of 0 dB.
Y-axis: OFDM Symbol Power
X-axis: Time (OFDM Symbol units)



Frame Structure Screen (LTE-Advanced)

Optional

MS269xA

MS2830A

Easy Setup Screen (System = LTE)

Test Type Setting Range

Display	Outline	Setting Range
Test Type	Sets the Test Type.	E-UTRA Test Models, FRC (UL)

BS Test/E-UTRA Test Models Setting Range

Display	Outline	Setting Range
Common		
E-UTRA Test Models	Sets the E-UTRA Test Models.	E-TM1.1, E-TM1.2, E-TM2, E-TM2a, E-TM3.1, E-TM3.1a, E-TM3.2, E-TM3.3
Bandwidth	Sets the system bandwidth.	1.4, 3, 5, 10, 15, 20 MHz
Cell ID	Sets the Cell ID.	0 to 503
Filter	Sets filter.	Ideal, None

BS Test/FRC (UL) Setting Range

Display	Outline	Setting Range
Common		
FRC (UL)	Selects the setting items described in 3GPP TS 36.141 Annex A and automatically sets the parameters.	A1-1, A1-2, A1-3, A1-4, A1-5, A2-1, A2-2, A2-3
Bandwidth	Sets the system bandwidth.	The settable bandwidth changes according to the selected FRC (UL).
Cell ID	Sets the Cell ID.	0 to 503
Roll Off Length	Sets the length of the ramp time applied to the OFDM symbol.	0 to 144
Filter	Sets the filter type.	Ideal, None
PUSCH		
Start Number of RB	Sets the start position of the RB to which the PUSCH is assigned.	Bandwidth = 1.4 MHz: 0 to (6-allocated resource block) Bandwidth = 3 MHz: 0 to (15-allocated resource block) Bandwidth = 5 MHz: 0 to (25-allocated resource block) Bandwidth = 10 MHz: 0 to (50-allocated resource block) Bandwidth = 15 MHz: 0 to (75-allocated resource block) Bandwidth = 20 MHz: 0 to (100-allocated resource block)
nRNTI	Sets the radio network temporary identifier.	0 to FFFF
Modulation	Sets the modulation mode.	QPSK, 16QAM, 64QAM
UL-SCH		
Transport Block Size	Sets the transport block size for UL-SCH.	0 to 86400
Data Type	Sets the Data type.	PN9fix, PN15fix, All0, All1
DMRS for PUSCH		
Group Hopping	Enables or disables group hopping.	Off, On
Sequence Hopping	Enables or disables Sequence Hopping.	Off, On
Delta ss	Sets Delta ss.	0 to 29
n(1)_DMRS	Sets the value used for automatic n_cs calculation.	0, 2, 3, 4, 6, 8, 9, 10
n(2)_DMRS	Sets the value used for automatic n_cs calculation.	0, 2, 3, 4, 6, 8, 9, 10
Sounding RS		
SRS	Enables or disables the Sounding RS parameter.	Off, On
SRS Subframe Configuration	Sets the SRS Subframe Configuration.	0 to 14

Easy Setup Screen (System = LTE-Advanced)

Test Type Setting Range

Display	Outline	Setting Range
Test Type	Sets the Test Type	E-UTRA Test Models, FRC (UL)

BS Test/E-UTRA Test Models Setting Range

Display	Outline	Setting Range
E-UTRA Test Models	Sets the E-UTRA Test Models	E-TM1.1, E-TM1.2, E-TM2, E-TM2a, E-TM3.1, E-TM3.1a, E-TM3.2, E-TM3.3
Bandwidth	Sets the system bandwidth	1.4, 3, 5, 10, 15, 20 MHz
Cell ID	Sets the Cell ID	0 to 503
Roll Off Length	Sets the length of the ramp time applied to the OFDM symbol	0 to 144
Filter	Sets filter	Ideal, None

BS Test/FRC (UL) Setting Range

Display	Outline	Setting Range
Common		
FRC (UL)	Selects the setting items described in 3GPP TS 36.141 Annex A and automatically sets the parameters	A1-1, A1-2, A1-3, A1-4, A1-5, A2-1, A2-2, A2-3
Bandwidth	Sets the system bandwidth	The settable bandwidth changes according to the selected FRC (UL)
Cell ID	Sets the Cell ID	0 to 503
Roll Off Length	Sets the length of the ramp time applied to the OFDM symbol	0 to 144
Filter	Sets the filter type	Ideal, None

LTE IQproducer MX269908A/LTE-Advanced FDD Option MX269908A-001

Optional

MS269xA

MS2830A

Display	Outline	Setting Range
PUSCH		
Start Number of RB	Sets the start position of the RB to which the PUSCH is assigned	Bandwidth = 1.4 MHz: 0 to (6-allocated resource block) Bandwidth = 3 MHz: 0 to (15-allocated resource block) Bandwidth = 5 MHz: 0 to (25-allocated resource block) Bandwidth = 10 MHz: 0 to (50-allocated resource block) Bandwidth = 15 MHz: 0 to (75-allocated resource block) Bandwidth = 20 MHz: 0 to (100-allocated resource block)
nRNTI	Sets the radio network temporary identifier	0 to FFFF
Modulation	Sets the modulation mode	QPSK, 16QAM, 64QAM
UL-SCH		
Transport Block Size	Sets the transport block size for UL-SCH	0 to 86400
Data Type	Sets the Data type	PN9fix, PN15fix, All0, All1
DMRS for PUSCH		
Group Hopping	Enables or disables group hopping	Off, On
Sequence Hopping	Enables or disables Sequence Hopping	Off, On
Delta ss	Sets Delta ss	0 to 29
n (1)_DMRS	Sets the value used for automatic n_cs calculation	0, 2, 3, 4, 6, 8, 9, 10
n (2)_DMRS	Sets the value used for automatic n_cs calculation	0, 2, 3, 4, 6, 8, 9, 10
Sounding RS		
SRS	Enables or disables the Sounding RS parameter	Off, On
SRS Subframe Configuration	Sets the SRS Subframe Configuration	0 to 14

Carrier Aggregation Mode Setting Range

Display	Outline	Setting Range														
Carrier Aggregation Mode	Sets the Carrier Aggregation Mode	Intra-band, Inter-band														
Parameter																
Component Carrier	Displays the Component Carrier number	Display only														
Status	Enables or disables the Component Carrier parameter	Check box selected, or cleared														
Bandwidth	Displays the system bandwidth for the Component Carrier	Display only														
Cell ID	Displays the cell ID for the Component Carrier	Display only														
Gain	Sets the level ratio of Component Carrier	-80.00 to 0.00 [dB]														
Freq.Offset	Sets the frequency offset	0 to $\pm (0.4 \times F_s - 0.5 \times \text{Band})$ [MHz] Band: Changed depending on the Component Carrier# transmission system bandwidth (Bandwidth) <table border="1" style="margin-left: 20px;"> <thead> <tr> <th>Bandwidth [MHz]</th> <th>Band [MHz]</th> </tr> </thead> <tbody> <tr> <td>1.4</td> <td>1.095</td> </tr> <tr> <td>3.0</td> <td>2.715</td> </tr> <tr> <td>5.0</td> <td>4.515</td> </tr> <tr> <td>10.0</td> <td>9.015</td> </tr> <tr> <td>15.0</td> <td>13.515</td> </tr> <tr> <td>20.0</td> <td>18.015</td> </tr> </tbody> </table> Fs: 153.6 MHz (sampling rate)	Bandwidth [MHz]	Band [MHz]	1.4	1.095	3.0	2.715	5.0	4.515	10.0	9.015	15.0	13.515	20.0	18.015
Bandwidth [MHz]	Band [MHz]															
1.4	1.095															
3.0	2.715															
5.0	4.515															
10.0	9.015															
15.0	13.515															
20.0	18.015															
Phase	Sets the initial phase of the Component Carrier	0 to 359 [deg.]														
Delay	Sets delay of the Component Carrier	0 to 307200 [Ts]														
BS Test Type	Sets the details of BS Test Type of Component Carriers	BS Test/E-UTRA Test Models, BS Test/FRC(UL)														

Pattern Setting Setting Range

Display	Outline	Setting Range
Package	Enters waveform pattern package name	Up to 31 single-byte English alphanumeric characters
Export File Name	Enters waveform pattern file name	Carrier Aggregation Mode = Intra-band : Up to 18 single-byte English alphanumeric characters Carrier Aggregation Mode = Inter-band : Up to 15 single-byte English alphanumeric characters
Comment	Inputs comments to the waveform pattern	Up to 38 single-byte English alphanumeric characters \times 3 lines

Normal Setup Screen

Display	Outline	Setting Range
System	Switches 3GPP Systems	LTE, LTE-Advanced

Common Parameter Setting Range (System = LTE)

Display	Outline	Setting Range
Common		
Number of Antennas	Sets number of antennas	1, 2, 4 (2 and 4 only at Downlink)
Diversity Method	Sets diversity method	Spatial Multiplexing, Tx Diversity
Precoding Method	Sets precoding method	Without CDD, Large-delay CDD, Large-delay CDD (Cyclic Precoder Index)
Number of Layers	Sets number of layers	1, 2, 3, 4
Number of Code words	Sets number of Code word	1, 2
Codebook index	Sets codebook index	When Number of Layers is 1: 0 to 3 When Number of Layers is 2: 0 to 2 When Number of Antennas is 4: 0 to 15
Physical-layer Cell-identity Group NID (1)	Sets physical-layer cell-identity group NID (1)	0 to 167
Physical-layer Identity NID (2)	Sets physical-layer identity NID (2)	0, 1, 2
Cell ID	Displays cell ID	0 to 503
Number of Frames	Sets number of frames	1 to max. number of frames in memory
Over Sampling Ratio	Sets over sampling ratio	2, 4
Sampling Rate	Displays sampling rate	Display only: Auto-setting using Over Sampling Ratio and bandwidth
Bandwidth	Sets system bandwidth	1.4, 3.0, 5, 10, 15, 20 MHz*
Downlink/Uplink	Sets downlink/uplink settings	Downlink, Uplink
Cyclic Prefix	Sets cyclic prefix	Normal, Extended
Subcarrier Spacing	Displays subcarrier spacing	Display only
Number of OFDM symbols per slot	Displays number of OFDM symbols per slot	7 (only when Cyclic Prefix = Normal), 6 (only when Cyclic Prefix = Extended)
Roll Off Length	Sets roll-off length for OFDM symbol	0 to 3152 Ts (when Random Access Preamble) 0 to 144 Ts (when Cyclic Prefix = Normal) 0 to 512 Ts (when Cyclic Prefix = Extended)
Filter		
Filter Type	Sets filter type	Nyquist, Root Nyquist, Ideal, None
Roll Off	Sets roll-off rate	0.1 to 1.0 (only enabled for Nyquist, Root Nyquist)

*: The 1.6 MHz and 3.2 MHz settings are not available for IQproducer Version 10.00 or later. In addition, parameter files for versions earlier than IQproducer Version 10.00 in which 1.6 MHz or 3.2 MHz is specified cannot be read.

Common Parameter Setting Range (System = LTE-Advanced)

Display	Outline	Setting Range
Carrier Aggregation Mode	Sets the Carrier Aggregation Mode	Intra-band, Inter-band
Downlink/Uplink	Sets downlink or uplink	Downlink, Uplink

PHY/MAC Parameter Setting Range (LTE-Advanced)

Display	Outline	Setting Range														
Carrier Aggregation																
Component Carrier	Displays the Component Carrier number	0 to 4														
Status	Enables or disables the Component Carrier parameter	Check box selected, or cleared														
Bandwidth	Displays the system bandwidth for the Component Carrier	Display only														
Cell ID	Displays the Cell ID for the Component Carrier	Display only														
Gain	Sets the level ratio of Component Carrier	-80.00 to 0.00 [dB]														
Freq.Offset	Sets the frequency offset	0 to $\pm(0.4 \times F_s - 0.5 \times \text{Band})$ [MHz] Band: Changed depending on the Component Carrier transmission system bandwidth (Bandwidth) <table border="1" style="margin-left: 20px;"> <thead> <tr> <th>Bandwidth [MHz]</th> <th>Band [MHz]</th> </tr> </thead> <tbody> <tr> <td>1.4</td> <td>1.095</td> </tr> <tr> <td>3.0</td> <td>2.715</td> </tr> <tr> <td>5.0</td> <td>4.515</td> </tr> <tr> <td>10.0</td> <td>9.015</td> </tr> <tr> <td>15.0</td> <td>13.515</td> </tr> <tr> <td>20.0</td> <td>18.015</td> </tr> </tbody> </table> Fs: 153.6 MHz (sampling rate)	Bandwidth [MHz]	Band [MHz]	1.4	1.095	3.0	2.715	5.0	4.515	10.0	9.015	15.0	13.515	20.0	18.015
Bandwidth [MHz]	Band [MHz]															
1.4	1.095															
3.0	2.715															
5.0	4.515															
10.0	9.015															
15.0	13.515															
20.0	18.015															
Phase	Sets the initial phase of the Component Carrier	0 to 359 [deg.]														
Delay	Sets delay of the Component Carrier	0 to 307200 [Ts]														
Component Carrier																
Number of Antennas	Sets the number of antennas	1, 2, 4														
Diversity Method	Sets the diversity method	Spatial Multiplexing, Tx Diversity														
Precoding Method	Sets the precoding method	Without CDD, Large-delay CDD, Large-delay CDD (Cyclic Precoder Index)														
Number of Layers	Sets the number of layers	1, 2, 3, 4														
Number of Code words	Sets the number of code words	1, 2														

LTE IQproducer MX269908A/LTE-Advanced FDD Option MX269908A-001

Optional

MS269xA

MS2830A

Display	Outline	Setting Range
Codebook index	Sets the codebook index	When Number of Antennas is 2, the setting range varies according to Number of Layers as follows When Number of Layers is 1: 0 to 3 When Number of Layers is 2: 0 to 2 When Number of Layers is 4: 0 to 15
NID (1)	Sets the NID (1)	0 to 167
NID (2)	Sets the NID (2)	0, 1, 2
Cell ID	Sets the Cell ID	0 to 503
Number of Frames	Sets the number of frames to be generated	1 to the maximum number of frames that can be stored in the main unit's waveform memory
Over Sampling Ratio	Sets the oversampling ratio	1, 2, 4
Sampling Rate	Displays the sampling rate	Display only: automatically set according to the Oversampling Ratio and Bandwidth values
Bandwidth	Sets the system bandwidth	1.4, 3, 5, 10, 15, 20 MHz
Cyclic Prefix	Sets the cyclic prefix	Normal, Extended
Subcarrier Spacing	Displays the subcarrier spacing (interval)	Display only
Number of OFDM symbols per slot	Sets the number of OFDM symbols per slot	Display only
Roll Off Length	Sets the length of the ramp time applied to the OFDM symbol	0 to 3152 Ts (Random Access Preamble) 0 to 144 Ts (Cyclic prefix = Normal) 0 to 512 Ts (Cyclic prefix = Extended)
Filter		
Filter Type	Sets the filter type	Nyquist, Root Nyquist, Ideal, None
Roll Off	Sets the roll-off factor	0.1 to 1.0

PHY/MAC Parameter (Downlink) Setting Range

Display	Outline	Setting Range
Downlink		
PHICH	Sets ON/OFF for PHICH	ON, OFF
PHICH duration	Sets the PHICH area	Normal, Extended
Ng	Sets the parameter (Ng) for determining the PHICH arrangement	1/6, 1/2, 1, 2
Reference Signal		
Reference Signal Sequence	Sets data used as reference signal sequence	Gold Sequence, PN9fix, PN15fix, 16bit repeat, User File
Reference Signal Sequence Repeat Data	Sets 16bit repeat data installed in reference signal sequence	0000 to FFFF (only when reference signal sequence = 16bit repeat)
Reference Signal Sequence User File	Sets user file installed in reference signal sequence	Select any file (only when reference signal sequence = User File)
Frequency Shift Value	Displays frequency shift	0, 1, 2, 3, 4, 5
Power Boosting	Sets power boosting	-20.000 to +20.000 dB
PBCH		
Data Status	Enables/disables PBCH parameter	Disable, Enable
Data Type	Sets data type	PN9fix, PN15fix, 16bit repeat, User File, BCH
Data Type Repeat Data	Sets 16bit repeat data	0000 to FFFF (only when Data Type = 16bit repeat)
Data Type User File	Sets user file	Select any file (only when Data Type = User File)
Power Boosting	Sets power boosting	-20.000 to +20.000 dB
BCH		
Data Type	Sets data type	PN9fix, PN15fix, 16bit repeat, User File, BCCH
Data Type Repeat Data	Sets 16bit repeat data installed in BCH	0000 to FFFF (only when Data Type = 16bit repeat)
Data Type User File	Sets user file to install in BCH	Select any file (only when Data Type = User File)
Transport Block Size	Sets number of bits required for BCH	When Cyclic Prefix = Normal, Max. 1920 When Cyclic Prefix = Extended, Max. 1728
DL Bandwidth	Displays data mapped to BCCH	n6, n15, n25, n50, n75, n100
PHICH duration	Displays the PHICH duration mapped to BCCH	Normal, Extended
Ng	Displays the Ng value mapped to BCCH	1/6, 1/2, 1, 2
SFN Offset	Sets the initial SFN value mapped to BCCH	0 to 1023
Synchronization Signals		
Primary Synchronization Signal		
Data Status	Enables/disables primary synchronization signal parameter	Disable, Enable
Data Type	Sets data type	Zadoff-Chu Sequence, User File
Data Type User File	Sets user file to install in primary synchronization signal	Select any file (only when Data Type = User File)
Zadoff-Chu Sequence index u	Displays Zadoff-Chu Sequence index u	25, 29, 34
Power Boosting	Sets power boosting	-20.000 to +20.000 dB
Secondary Synchronization Signal		
Data Status	Enables/disables secondary synchronization signal parameter	Disable, Enable
Data Type	Sets data type	Concatenated sequence, PN9fix, PN15fix, 16bit repeat, User File
Data Type Repeat Data	Sets 16bit repeat data	0000 to FFFF (only when Data Type = 16bit repeat)
Data Type User File	Sets user file	Select any file (only when Data Type = User File)
Power Boosting	Sets power boosting	-20.000 to +20.000 dB

LTE IQproducer MX269908A/LTE-Advanced FDD Option MX269908A-001

Optional

MS269xA

MS2830A

Display	Outline	Setting Range
Subframe#0 to #9		
Virtual Resource Block type	Sets the Virtual Resource Block	Localized, Distributed
Gap	Sets Gap	1st Gap, 2nd Gap
Gap value	Sets Gap value	3 to 48
Number of VRBs	Displays the number of VRB	6 to 96
Number of PHICH Groups	Sets PHICH Groups in one subframe	Display only (determined by the combination of Bandwidth, Ng, and Cyclic Prefix. It is fixed to 0 when PHICH is Off.)
Number of OFDM symbols for PDCCH	Sets number of OFDM symbols for PDCCH	1 to 4
Total Number of CCEs	Display Total Number of CCE	Display only
Number of PDCCHs	Sets number of PDCCHs	1 to 64
CCE arrangement	Sets CCE arrangement	PDCCH#0 to (Number of PDCCHs - 1), dummy
Number of PDSCHs	Sets number of PDSCHs	1 to 64
RB arrangement	Sets RB arrangement	PDSCH#0 to Number of PDSCHs - 1
VRB arrangement	Sets the VRB arrangement	PDSCH#0 to (Number of VRBs - 1)
PCFICH		
Data Status	Enables/disables PCFICH parameter	Disable, Enable
Data Type	Sets data type	CFI codeword, PN9fix, PN15fix, 16bit repeat, User File
CFI	Sets CFI codeword type	1, 2, 3
Data Type Repeat Data	Sets 16bit repeat data	0000 to FFFF (only when Data Type = 16bit repeat)
Data Type User File	Sets user file	Select any file (only when Data Type = User File)
Power Boosting	Sets power boosting	-20.000 to +20.000 dB
PDCCH		
Data Status	Enables/disables PDCCH Parameter	Disable, Enable
PDCCH format	Sets PDCCH format	0, 1, 2, 3
Data Type	Sets data type	PN9fix, PN15fix, 16bit repeat, User File, DCI
Data Type Repeat Data	Sets 16bit repeat data	0000 to FFFF (only when Data Type = 16bit repeat)
Data Type User File	Sets user file	Select any file (only when Data Type = User File)
Power Boosting	Sets power boosting	-20.000 to +20.000 dB
DCI		
Data Type	Sets data type	PN9fix, PN15fix, 16bit repeat, User File
Data Type Repeat Data	Sets 16bit repeat data	0000 to FFFF (only when Data Type = 16bit repeat)
Data Type User File	Sets user file	Select any file (only when Data Type = User File)
Transport Block Size	Sets number of bits required for DCI	0 to 576
nRNTI	Sets Radio network temporary identifier	0000 to FFFF
PDSCH		
Data Status	Enables/disables PDSCH parameter	Disable, Enable
nRNTI	Sets Radio network temporary identifier	0000 to FFFF
Modulation Scheme	Sets modulation scheme	QPSK, 16QAM, 64QAM, 256QAM
Data Type	Sets data type	PN9fix, PN15fix, 16bit repeat, User File, DL-SCH
Data Type Repeat Data	Sets 16bit repeat data	0000 to FFFF (only when Data Type = 16bit repeat)
Data Type User File	Sets user file	Select any file (only when Data Type = User File)
Power Boosting	Sets power boosting	-20.000 to +20.000 dB
DL-SCH		
Data Type	Sets data type	PN9fix, PN15fix, 16bit repeat, User File
Data Type Repeat Data	Sets 16bit repeat data	0000 to FFFF (only when Data Type = 16bit repeat)
Data Type User File	Sets user file	Select any file (only when Data Type = User File)
Transport Block Size	Sets number of bits required for DL-SCH	Changes max. value of setting range by number of Resource Blocks and the modulation scheme
UE Category	Sets UE Category	1, 2, 3, 4, 5
RV Index	Sets redundancy version index	0, 1, 2, 3
PHICH		
Data Status	Enable/disables PHICH parameter	Disable, Enable
PHICH Group number	Display PHICH Group number	Display only
Number of PHICHs	Sets Number of PHICHs	1 to 8 (Cyclic Prefix = Normal) 1 to 4 (Cyclic Prefix = Extended)
Power Boosting	Set power boosting	Display only
PHICH#0 to # (Number of PHICHs-1)		
Data Status	Enable/disable PHICH parameter	Disable, Enable
Orthogonal Sequence Index	Sets orthogonal sequence index	0 to 7 (When Cyclic Prefix = Normal) 0 to 3 (When Cyclic Prefix = Extended)
Data Type	Display data type	Display only: HI codeword
HI	Sets code word of HI (HARQ indicator)	000, 111
Power Boosting	Set power boosting	-20.000 to +20.000 dB

LTE IQproducer MX269908A/LTE-Advanced FDD Option MX269908A-001

Optional

MS269xA

MS2830A

PHY/MAC Parameter (Uplink) Setting Range

Display	Outline	Setting Range
Uplink		
Data Transmission/Random Access Preamble	Selects Data Transmission or Random Access Preamble	Data Transmission/Random Access Preamble
DMRS Parameters	Sets the calculation method of Demodulation RS parameter.	Auto, Manual
PUCCH Parameters		
delta PUCCH shift	Sets delta PUCCH shift	1, 2, 3
N_CS(1)	Sets the value of N_CS(1), which is the number of cyclic shifts used in the PUCCH formats 1, 1a, and 1b	0 to 7
N_RB(2)	Sets the value of N_RB(2), which is the number of resource blocks used in the PUCCH formats 2, 2a, and 2b	0 to 63
Sounding RS Parameters		
SRS	Sets SRS ON/OFF	ON, OFF
SRS Subframe Configuration	Sets the SRS Subframe Configuration	0 to 14
Subframe#0 to #9 (Data Transmission)		
Number of PUCCHs	Sets number of PUCCH	0, 1, 2, 3, 4, 5, 6, 7, 8
Number of PUSCHs	Sets number of PUSCH	0, 1, 2, 3, 4, 5, 6, 7, 8
PUCCH#0 to #7		
Data Status	Enables/disables PUCCH parameter	Disable, Enable
n(1)_PUCCH	Sets the resource number for PUCCH 1, 1a, and 1b	0 to 764
n(2)_PUCCH	Sets the resource number for PUCCH 2, 2a, and 2b	0 to 764
nRNTI	Sets Radio network temporary identifier	0000 to FFFF
PUCCH format	Sets PUCCH format	1, 1a, 1b, 2, 2a, 2b
Data Type	Sets data type	PN9fix, PN15fix, 16bit repeat, User File, UCI
Data Type Repeat Data	Sets 16bit repeat data	0000 to FFFF (only when Data Type = 16bit repeat)
Data Type User File	Sets user file	Select any file (only when Data Type = User File)
Group Hopping	Enables or disables group hopping	Disable, Enable
Base Sequence Group Number u	Sets base sequence group number	0 to 29
Base Sequence Number v	Displays base sequence number	0 fixed
Power Boosting	Sets power boosting	-20.000 to +20.000 dB
UCI		
Transport Block Size	Sets transport block size of UCI	1 (When PUCCH format = 1a) 2 (When PUCCH format = 1b) 1 to 13 (When PUCCH format = 2) 2 to 14 (When PUCCH format = 2a) 3 to 15 (When PUCCH format = 2b)
Data Type	Sets data type	PN9fix, PN15fix, 16bit repeat, User File
Data Type Repeat Data	Sets 16bit repeat data	0000 to FFFF (only when Data Type = 16bit repeat)
Data Type User File	Sets user file	Select any file (only when Data Type = User File)
Demodulation RS for PUCCH		
Data Type	Sets data type	Base Sequence, User File
Data Type User File	Sets user file	Select any file (only when Data Type = User File)
Group Hopping	Enable/disable Group Hopping parameter	Disable, Enable
Base Sequence Group Number u	Sets base sequence group number	0 to 29
Base Sequence Number v	Displays base sequence group number	0 fixed
PUSCH#0 to #7		
Data Status	Enables/disables PUSCH parameter	Disable, Enable
nRNTI	Sets Radio network temporary identifier	0000 to FFFF
Modulation Scheme	Sets modulation system	QPSK, 16QAM, 64QAM
Data Type	Sets data type	PN9fix, PN15fix, 16bit repeat, User File, UL-SCH
Data Type Repeat Data	Sets 16bit repeat data	0000 to FFFF (only when Data Type = 16bit repeat)
Data Type User File	Sets user file	Select any file (only when Data Type = User File)
Resource allocation type	Sets the Resource allocation type	type0, type1 When type1 is selected, Start Number of RB and Number of RBs cannot be set
Start Number of RB	Start position of RB	When Bandwidth is 1.4 MHz: 0 to 5 When Bandwidth is 3 MHz: 0 to 14 When Bandwidth is 5 MHz: 0 to 24 When Bandwidth is 10 MHz: 0 to 49 When Bandwidth is 15 MHz: 0 to 74 When Bandwidth is 20 MHz: 0 to 99
Number of RBs	Total number of RB	When Bandwidth is 1.4 MHz: 1 to 6 When Bandwidth is 3 MHz: 1 to 15 When Bandwidth is 5 MHz: 1 to 25 When Bandwidth is 10 MHz: 1 to 50 When Bandwidth is 15 MHz: 1 to 75 When Bandwidth is 20 MHz: 1 to 100

LTE IQproducer MX269908A/LTE-Advanced FDD Option MX269908A-001

Optional

MS269xA

MS2830A

Display	Outline	Setting Range																					
Start Number of RBG for 1st	Sets the start position of the RBG for 1st	<p>The setting range varies depending on the Bandwidth setting as follows</p> <table border="1"> <thead> <tr> <th>Bandwidth (Number of RBs)</th> <th>Setting range*</th> </tr> </thead> <tbody> <tr> <td>1.4 MHz (6)</td> <td>1 to 4</td> </tr> <tr> <td>3 MHz (15)</td> <td>1 to 6</td> </tr> <tr> <td>5 MHz (25)</td> <td>1 to 11</td> </tr> <tr> <td>10 MHz (50)</td> <td>1 to 15</td> </tr> <tr> <td>15 MHz (75)</td> <td>1 to 17</td> </tr> <tr> <td>20 MHz (100)</td> <td>1 to 23</td> </tr> </tbody> </table> <p>*: The maximum value of the setting range is smaller than End Number of RBG for 1st + 1</p>	Bandwidth (Number of RBs)	Setting range*	1.4 MHz (6)	1 to 4	3 MHz (15)	1 to 6	5 MHz (25)	1 to 11	10 MHz (50)	1 to 15	15 MHz (75)	1 to 17	20 MHz (100)	1 to 23							
Bandwidth (Number of RBs)	Setting range*																						
1.4 MHz (6)	1 to 4																						
3 MHz (15)	1 to 6																						
5 MHz (25)	1 to 11																						
10 MHz (50)	1 to 15																						
15 MHz (75)	1 to 17																						
20 MHz (100)	1 to 23																						
End Number of RBG for 1st	Sets the end position of the RBG for 1st	<p>The setting range varies depending on the Bandwidth setting as follows</p> <table border="1"> <thead> <tr> <th>Bandwidth (Number of RBs)</th> <th>Setting range*</th> <th>Default</th> </tr> </thead> <tbody> <tr> <td>1.4 MHz (6)</td> <td>1 to 4</td> <td>3</td> </tr> <tr> <td>3 MHz (15)</td> <td>1 to 6</td> <td>3</td> </tr> <tr> <td>5 MHz (25)</td> <td>1 to 11</td> <td>6</td> </tr> <tr> <td>10 MHz (50)</td> <td>1 to 15</td> <td>8</td> </tr> <tr> <td>15 MHz (75)</td> <td>1 to 17</td> <td>8</td> </tr> <tr> <td>20 MHz (100)</td> <td>1 to 23</td> <td>12</td> </tr> </tbody> </table> <p>*: The maximum value of the setting range is smaller than End Number of RBG for 1st + 1</p>	Bandwidth (Number of RBs)	Setting range*	Default	1.4 MHz (6)	1 to 4	3	3 MHz (15)	1 to 6	3	5 MHz (25)	1 to 11	6	10 MHz (50)	1 to 15	8	15 MHz (75)	1 to 17	8	20 MHz (100)	1 to 23	12
Bandwidth (Number of RBs)	Setting range*	Default																					
1.4 MHz (6)	1 to 4	3																					
3 MHz (15)	1 to 6	3																					
5 MHz (25)	1 to 11	6																					
10 MHz (50)	1 to 15	8																					
15 MHz (75)	1 to 17	8																					
20 MHz (100)	1 to 23	12																					
Start Number of RBG for 2nd	Sets the start position of the RBG for 2nd	<p>The setting range varies depending on the Bandwidth setting as follows</p> <table border="1"> <thead> <tr> <th>Bandwidth (Number of RBs)</th> <th>Setting range*</th> <th>Default</th> </tr> </thead> <tbody> <tr> <td>1.4 MHz (6)</td> <td>3 to 6</td> <td>5</td> </tr> <tr> <td>3 MHz (15)</td> <td>3 to 8</td> <td>5</td> </tr> <tr> <td>5 MHz (25)</td> <td>3 to 13</td> <td>8</td> </tr> <tr> <td>10 MHz (50)</td> <td>3 to 17</td> <td>10</td> </tr> <tr> <td>15 MHz (75)</td> <td>3 to 19</td> <td>10</td> </tr> <tr> <td>20 MHz (100)</td> <td>3 to 25</td> <td>14</td> </tr> </tbody> </table> <p>*: The maximum value of the setting range is smaller than End Number of RBG for 1st + 1</p>	Bandwidth (Number of RBs)	Setting range*	Default	1.4 MHz (6)	3 to 6	5	3 MHz (15)	3 to 8	5	5 MHz (25)	3 to 13	8	10 MHz (50)	3 to 17	10	15 MHz (75)	3 to 19	10	20 MHz (100)	3 to 25	14
Bandwidth (Number of RBs)	Setting range*	Default																					
1.4 MHz (6)	3 to 6	5																					
3 MHz (15)	3 to 8	5																					
5 MHz (25)	3 to 13	8																					
10 MHz (50)	3 to 17	10																					
15 MHz (75)	3 to 19	10																					
20 MHz (100)	3 to 25	14																					
End Number of RBG for 2nd	Sets the end position of the RBG for 2nd	<p>The setting range varies depending on the Bandwidth setting as follows</p> <table border="1"> <thead> <tr> <th>Bandwidth (Number of RBs)</th> <th>Setting range</th> <th>Default</th> </tr> </thead> <tbody> <tr> <td>1.4 MHz (6)</td> <td>3 to 6</td> <td>6</td> </tr> <tr> <td>3 MHz (15)</td> <td>3 to 8</td> <td>8</td> </tr> <tr> <td>5 MHz (25)</td> <td>3 to 13</td> <td>13</td> </tr> <tr> <td>10 MHz (50)</td> <td>3 to 17</td> <td>17</td> </tr> <tr> <td>15 MHz (75)</td> <td>3 to 19</td> <td>19</td> </tr> <tr> <td>20 MHz (100)</td> <td>3 to 25</td> <td>25</td> </tr> </tbody> </table>	Bandwidth (Number of RBs)	Setting range	Default	1.4 MHz (6)	3 to 6	6	3 MHz (15)	3 to 8	8	5 MHz (25)	3 to 13	13	10 MHz (50)	3 to 17	17	15 MHz (75)	3 to 19	19	20 MHz (100)	3 to 25	25
Bandwidth (Number of RBs)	Setting range	Default																					
1.4 MHz (6)	3 to 6	6																					
3 MHz (15)	3 to 8	8																					
5 MHz (25)	3 to 13	13																					
10 MHz (50)	3 to 17	17																					
15 MHz (75)	3 to 19	19																					
20 MHz (100)	3 to 25	25																					
Power Boosting	Sets power boosting	-20.000 to +20.000 dB																					
UL-SCH																							
Transport Block Size	Sets transport block size of UL-SCH	Changes max. value of the setting range by number of Resource Blocks																					
Data Type	Sets mapping data type	PN9fix, PN15fix, 16bit repeat, User File																					
Data Type Repeat Data	Sets 16bit repeat data	0000 to FFFF (only when Data Type = 16bit repeat)																					
Data Type User File	Sets user file	Select any file (only when Data Type = User File)																					
RV Index	Sets redundancy version index	0, 1, 2, 3																					
HARQ-ACK																							
Data Status	This enables or disables HARQ-ACK	Disable, Enable																					
Data Type	Sets the Data type to be inserted into the HARQ-ACK	ACK, NACK, ACK-ACK, ACK-NACK, NACK-ACK, NACK-NACK																					
Total Number of Coded Bits	Sets the number of bits after HARQ-ACK encoding	0 to Number of RBs × 288																					
RI																							
Data Status	Enables or disables the RI	Disable, Enable																					
Data Type	Sets the Data type to be inserted into the RI	1 (1 bit), 2 (1 bit), 1 (2 bits), 2 (2 bits), 3 (2 bits), 4 (2 bits)																					
Total Number of Coded Bits	Sets the number of bits after RI encoding	0 to Number of RBs × 288																					
CQI/PMI																							
Data Status	Enables or disables the CQI/PMI	Disable, Enable																					
Data Type	Sets the Data type to be inserted into the CQI/PMI	PN9fix, PN15fix, 16bit repeat, User File																					
Data Type Repeat Data	Sets the 16bit repeat data to be inserted into the CQI/PMI	0000 to FFFF (only when Data Type = 16bit repeat)																					
Data Type User File	Sets the User type to be inserted into the CQI/PMI	Select any file (only when Data Type = User File)																					
Total Number of Coded Bits	Sets the number of bits after CQI/PMI encoding	0 to 86400																					

LTE IQproducer MX269908A/LTE-Advanced FDD Option MX269908A-001

Optional

MS269xA

MS2830A

Display	Outline	Setting Range
Demodulation RS for PUSCH		
Data Type	Sets data installed in demodulation RS for PUSCH	Base Sequence, User File
Data Type User File	Sets user file	Select any file (only when Data Type = User File)
Group Hopping	Enable/disable Group Hopping parameter	Disable, Enable (only when Data Type = Base Sequence)
Sequence Hopping	Enables or disables Sequence Hopping	Disable, Enable
Delta ss	Sets Delta ss	0 to 29 (only when Data Type = Base Sequence)
Base Sequence Group Number u	Sets base sequence group number	0 to 29 (only when Data Type = Base Sequence)
Base Sequence Number v	Displays base sequence number	0, 1
Cyclic Shift		
n_cs Setting	Sets the Auto/Manual switching of n_cs setting	Auto, Manual
n(1)_DMRS	Sets the value used for automatic n_cs calculation	0, 2, 3, 4, 6, 8, 9, 10
n(2)_DMRS	Sets the value used for automatic n_cs calculation	0, 2, 3, 4, 6, 8, 9, 10
Cyclic Shift 1st slot		
n_cs	Sets n_cs for the first slot of Demodulation RS	0 to 11
alpha	Displays the cyclic shift of the first slot of Demodulation RS	The alpha value is calculated using the following equation, and the result is displayed to the 5th decimal point. $\alpha = 2 \times \pi \times n_cs / 12$
Cyclic Shift 2nd slot		
n_cs	Sets n_cs for the second slot of Demodulation RS	0 to 11
alpha	Displays the cyclic shift of the second slot of Demodulation RS	The alpha value is calculated using the following equation, and the result is displayed to the 5th decimal point. $\alpha = 2 \times \pi \times n_cs / 12$
Sounding RS		
Data Status	This enables or disables the Sounding RS parameter	Enable, Disable
Data Type	Sets the data to insert into Sounding RS	Base Sequence, User File
Data Type User File	This sets the user file to be inserted into Sounding RS	Select any file (only when Data Type = User File)
Group Hopping	Enables or disables group hopping	Disable, Enable (only when Data Type = Base Sequence)
Sequence Hopping	Enables or disables Sequence Hopping	Disable, Enable
Delta ss	Sets Delta ss	0 to 29
Base Sequence Group Number u	Sets the base sequence group number	0 to 29 (only when Data Type = Base Sequence)
Base Sequence Number v	Sets the base sequence number	0, 1 (only when Data Type = Base Sequence)
SRS Bandwidth Configuration	Sets SRS Bandwidth Configuration	0 to 7
SRS Bandwidth	Sets SRS Bandwidth	0 to 3
k_TC	Sets Transmission Comb	0, 1
SRS Hopping Bandwidth	Sets SRS Hopping Bandwidth	3 fixed
n_RRC	Sets Frequency Domain Position	0 to 23
Power Boosting	Sets the transmission power	-20.000 to +20.000 dB
Cyclic Shift		
n_SRS	Sets n_SRS	0 to 7
alpha	Displays Cyclic Shift	The alpha value is calculated using the following equation, and the result is displayed to the 5th decimal point. $\alpha = 2 \times \pi \times n_SRS / 8$
Random Access Preamble		
PRACH Configuration	Sets transmission timing of PRACH	0 to 63 (Except 30, 46, 60, 61, 62)
Preamble Format	Displays preamble format	Display only
Data Type	Sets data type	Root Zadoff-Chu Sequence, User File
Data Type User File	Sets user file	Select any file (only when Data Type = User File)
Root Zadoff-Chu Sequence	Sets Root Zadoff-Chu Sequence	1 to 839 (only when Data Type = Root Zadoff-Chu Sequence)
Cyclic Shift Value	Sets cyclic shift value	0 to 838 (only when Data Type = Root Zadoff-Chu Sequence)
Random Access Preamble Length	Displays length for random access preamble	Display only
Hopping Pattern Length	Sets frequency hopping pattern	1 to 10 frames
Hopping Pattern	Sets frequency hopping pattern for random access preamble in RB units	0 to 94, OFF
Power Ramping Step Size	Sets power increase step at each random access preamble transmission	0.0 to 10.0 dB

Easy Setup Parameter Setting Range

Display	Setting Range
BS Test	
E-UTRA Test Models	E-TM1.1, E-TM1.2, E-TM2, E-TM2a, E-TM3.1, E-TM3.1a, E-TM3.2, E-TM3.3
FRC	FRC (QPSK, R = 1/3): A1-1, A1-2, A1-3, A1-4, A1-5 FRC (16QAM, R = 2/3): A2-1, A2-2, A2-3 FRC (QPSK 1/3): A3-1, A3-2, A3-3, A3-4, A3-5, A3-6, A3-7 FRC (16QAM 3/4): A4-1, A4-2, A4-3, A4-4, A4-5, A4-6, A4-7, A4-8 FRC (64QAM 5/6): A5-1, A5-2, A5-3, A5-4, A5-5, A5-6, A5-7 PRACH Test Preambles: A6-1 (Burst format0, 1, 2, 3), A6-2 (Burst format0, 1, 2, 3) FRC (Scenario 1): A7-1, A7-1 (SRS Option), A7-2, A7-2 (SRS Option), A7-3, A7-3 (SRS Option), A7-4, A7-4 (SRS Option), A7-5, A7-5 (SRS Option), A7-6, A7-6 (SRS Option) FRC (Scenario 2): A8-1, A8-1 (SRS Option), A8-2, A8-2 (SRS Option), A8-3, A8-3 (SRS Option), A8-4, A8-4 (SRS Option), A8-5, A8-5 (SRS Option), A8-6, A8-6 (SRS Option)
UE Test	
RMC (DL)	FRC (Receiver Requirements) FRC (Maximum input level): Category 1, Category 2, Category 3-5 FRC (Tx Characteristics) FRC (QPSK, R = 1/3): R.4 FDD, R.2 FDD FRC (16QAM, R = 1/2): R.3 FDD FRC (64QAM, R = 3/4): R.5 FDD, R.6 FDD, R.7 FDD, R.8 FDD, R.9 FDD FRC (Single PRB): R.0 FDD, R.1 FDD FRC (two antenna ports): R.10 FDD, R.11 FDD FRC (four antenna ports): R.12 FDD, R.13 FDD, R.14 FDD FRC (FDD): R.15 FDD, R.16 FDD, R.17 FDD
RMC (UL)	Full RB (QPSK), Full RB (16QAM), Partial RB (QPSK), Partial RB (16QAM)

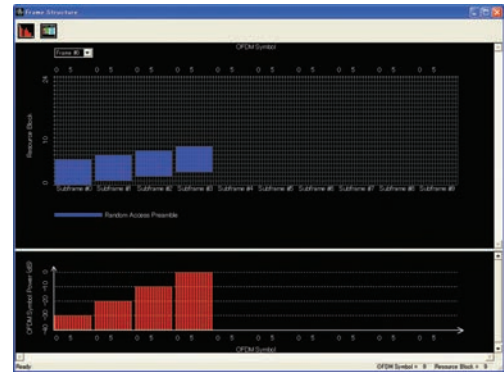
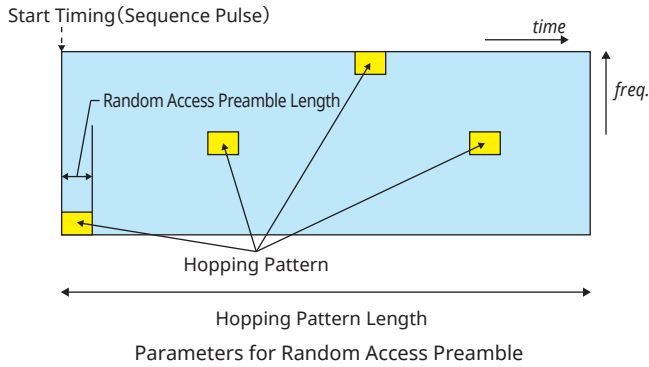

Random Access Preamble parameters setting

- PRACH Configuration : 0
- Data Type : Zadoff-Chu Sequence
- Root Zadoff-Chu Sequence : 1
- Cyclic Shift Value : 0
- Hopping Pattern Length : 1
- Hopping Pattern : RB#0, RB#1, RB#2, RB#3, OFF, OFF,
OFF, OFF, OFF, OFF
- Power Ramping Step Size : 10.0 dB

LTE TDD IQproducer MX269910A/LTE-Advanced TDD Option MX269910A-001

Optional

MS269xA

MS2830A

The LTE TDD IQproducer MX269910A is PC application software with a GUI for generating waveform patterns in compliance with the 3GPP LTE TDD specifications in the 3GPP TS 36.211, TS 36.212, TS 36.213, and TS 25.814 standards. Once created, the waveform pattern file is downloaded to the MS269xA or MS2840A/MS2830A hard drive. Using the MS269xA-020 or MS2840A/MS2830A-020/021, Vector Signal Generator Option functionality, the files are loaded, selected, and output as a modulated LTE signals. Generates test model waveform patterns used for LTE base station Tx tests and FRC (Fixed Reference Channel) used for Rx tests. LTE TDD IQproducer supports two setting screens: "Easy Setup Screen" and "Normal Setup Screen".

The LTE-Advanced TDD option MX269910A-001 supports simple generation of carrier aggregation signals added* by 3GPP Rel. 10. Additionally, clustered SC-FDMA signals can be generated at Uplink.

*: MBSFN reference signals, UE-specific reference signals, Positioning reference signals, CSI reference signals, Physical Multicast Channel, and Sounding Reference Signal are not supported.

Easy Setup Screen

Waveform patterns can be generated easily because the main parameters are restricted to the Easy Setup screen. Use "Normal Setup function" for detailed parameter settings.

Channels Generated by MX269910A

Downlink

- Cell-specific Reference Signal
- Primary Synchronization Signal
- Secondary Synchronization Signal
- PBCH (Physical Broadcast Channel)
- PCFICH (Physical Control Format Indicator Channel)
- PDCCH (Physical Downlink Control Channel)
- PDSCH (Physical Downlink Shared Channel)
- PHICH (Physical Hybrid-ARQ Indicator Channel)

Uplink

- PUCCH (Physical Uplink Control Channel)
- PUSCH (Physical Uplink Shared Channel)
- Demodulation Reference Signal for PUCCH/PUSCH
- PRACH (Physical Random Access Channel)

E-UTRA Test Models by Signal Type

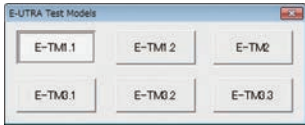

System

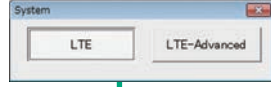

Test Type



Bandwidth

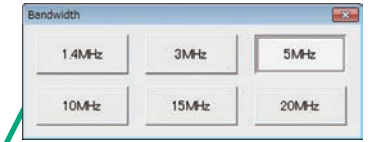

FRC (UL) by Signal Type



Filter

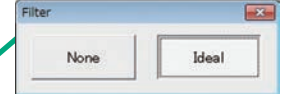

Data

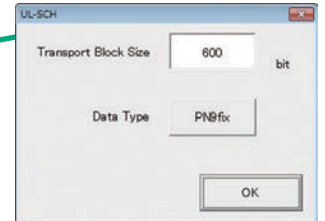

Modulation

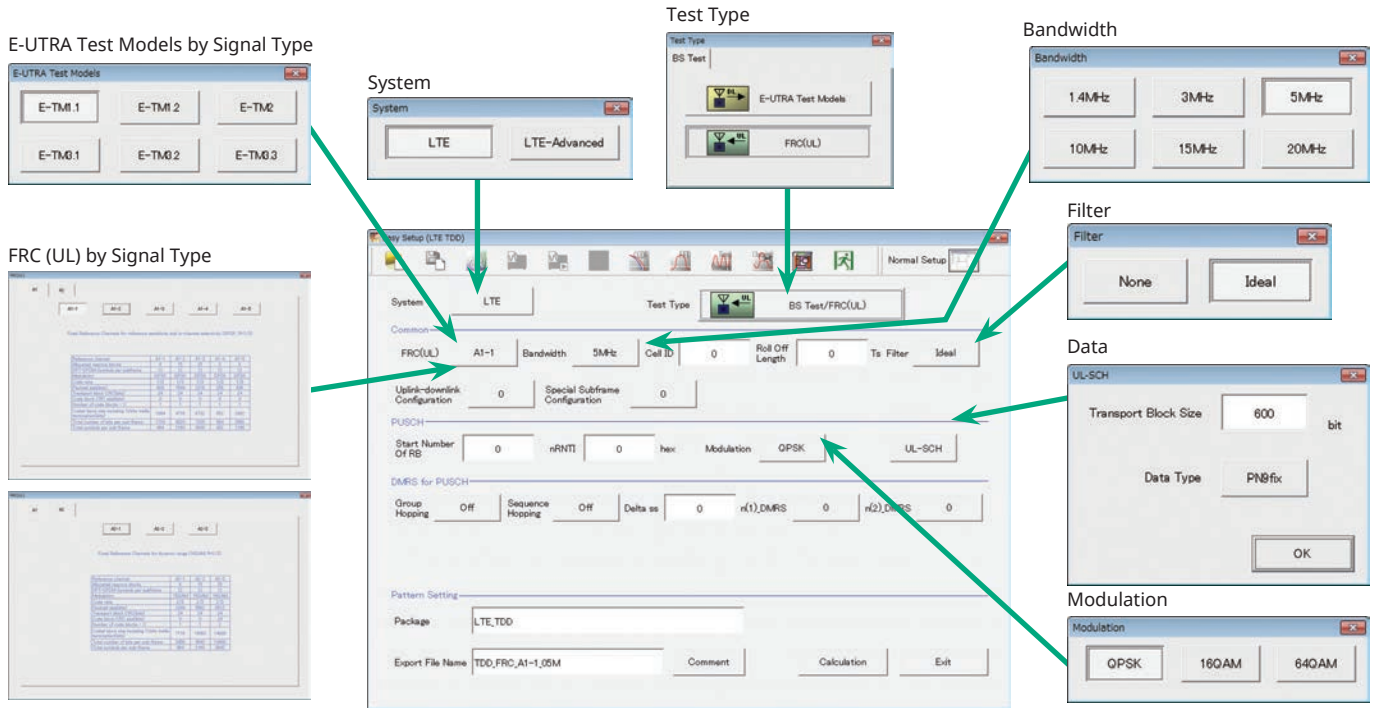
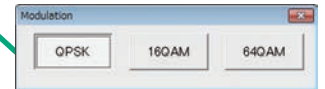

Easy Setup Screen (Example: FRC_UL)

Normal Setup Screen

Detailed parameters are set at the Normal Setup screen to generate waveform patterns.

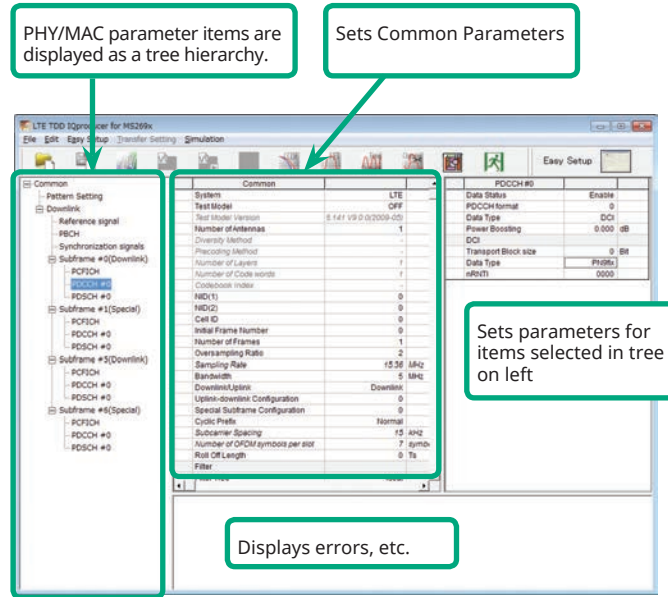

LTE TDD IQproducer Setting Screen/Normal Setup Screen

Easy Setup Menu

3GPP-defined test conditions can be selected from the Easy Setup menu tree to set values for the Normal Setup screen parameters.

BS Test/E-UTRA Test Models

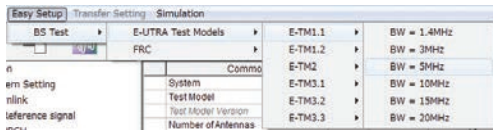

BS Test/FRC



Visual Check at Frame Structure Screen

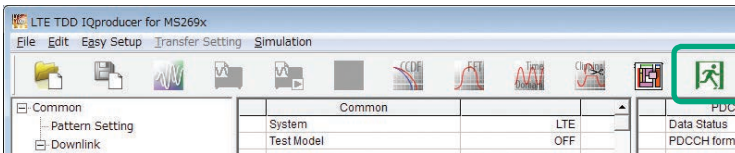

Displays Frame Structure screen for confirming channel allocation status and power of each OFDM Symbol

The Frame Structure Screen shows the resource element allocation graphically with each channel color-coded.
 Y-axis: Frequency (Resource Block units)
 X-axis: Time (OFDM Symbol units)
 In the Full Scale display, one frame (Subframe#0 to 9) is displayed.
 The zoom can be done by selecting the area with the cursor. When the Full Scale button is pushed, one frame is displayed. Moreover, when the cursor is set in each channel, and "Properties" is selected by right-clicking, information on the setting of the channel etc. is displayed.

The Power Graph shows the power relative levels of OFDM Symbols with maximum power of 0 dB.
 Y-axis: OFDM Symbol Power
 X-axis: Time (OFDM Symbol units)

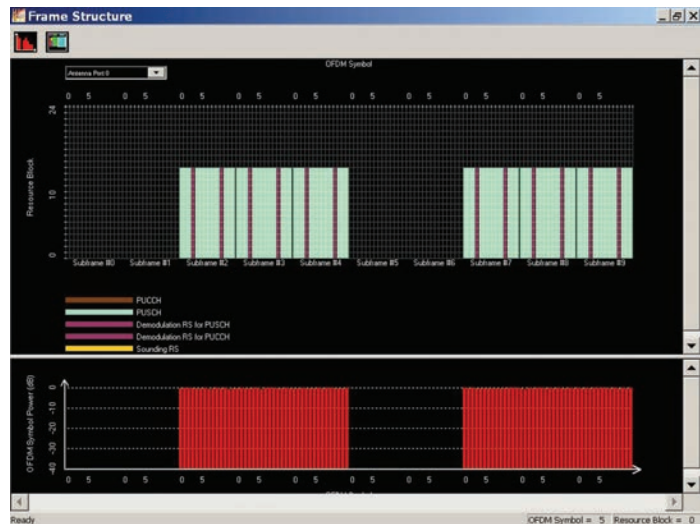

Frame Structure Screen (LTE)

LTE-Advanced TDD Option MX269910A-001

Adding the LTE-Advanced TDD option MX269910A-001 to set LTE-Advanced system parameters supports generation of carrier aggregation signals added* by 3GPP Rel. 10. Additionally, clustered SC-FDMA signals can be generated at Uplink.

*: MBSFN reference signals, UE-specific reference signals, Positioning reference signals, CSI reference signals, Physical Multicast Channel, and Sounding Reference Signal are not supported.

LTE-Advanced Setting Parameters Carrier Aggregation Mode

- Intra-band
Component Carrier #0 to #4
- Inter-band
Band #0, #1
Component Carrier #0 to #4

Easy Setup Screen

Waveform patterns can be generated easily by setting the band matching the carrier aggregation mode and component carrier because the main parameters are restricted to the Easy Setup screen. Use the "Normal Setup Function" for detailed parameter settings.

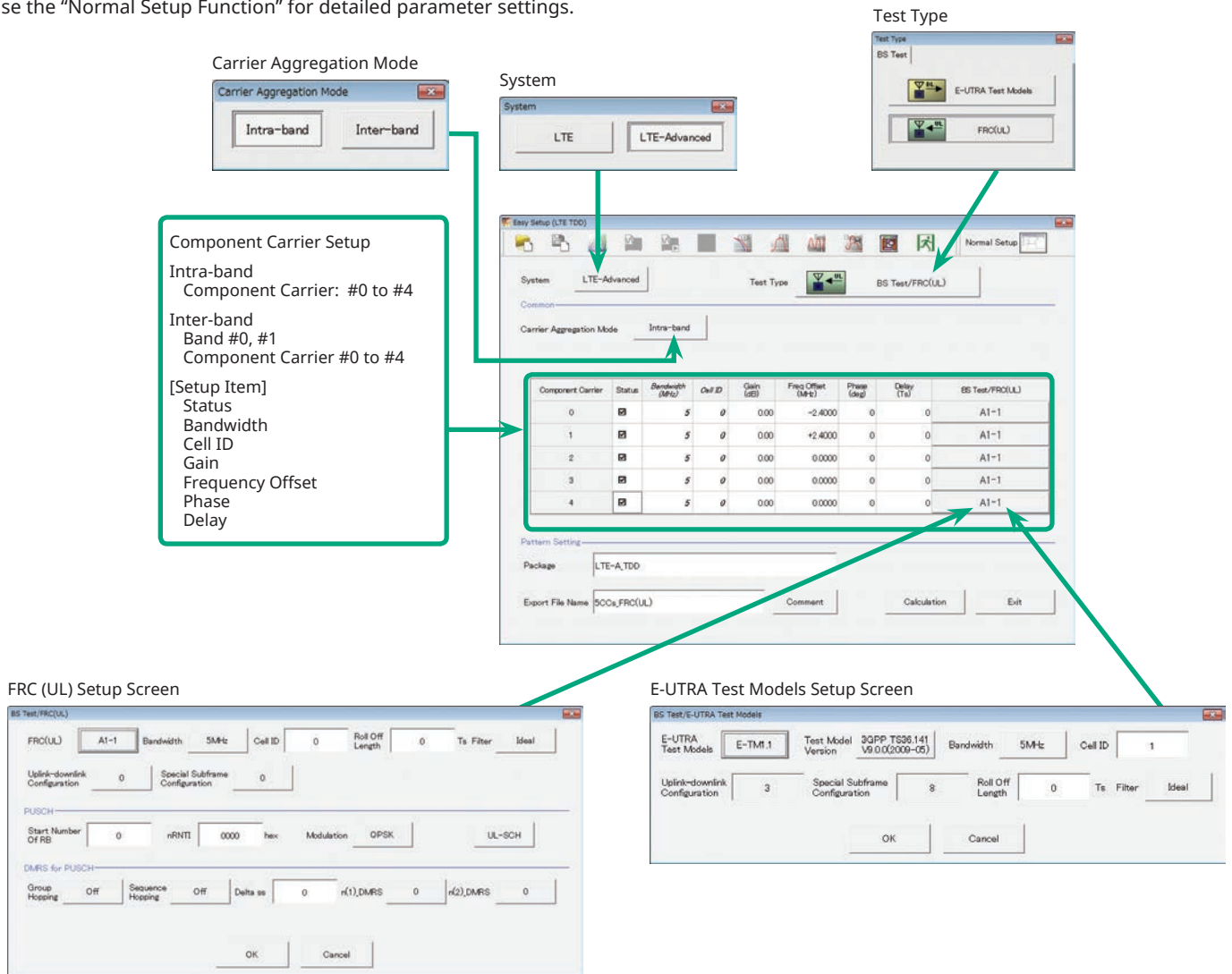

LTE-Advanced Easy Setup Screen (Example: FRC (UL))

Normal Setup Screen

Detailed parameters are set at the Normal Setup screen to generate waveform patterns.

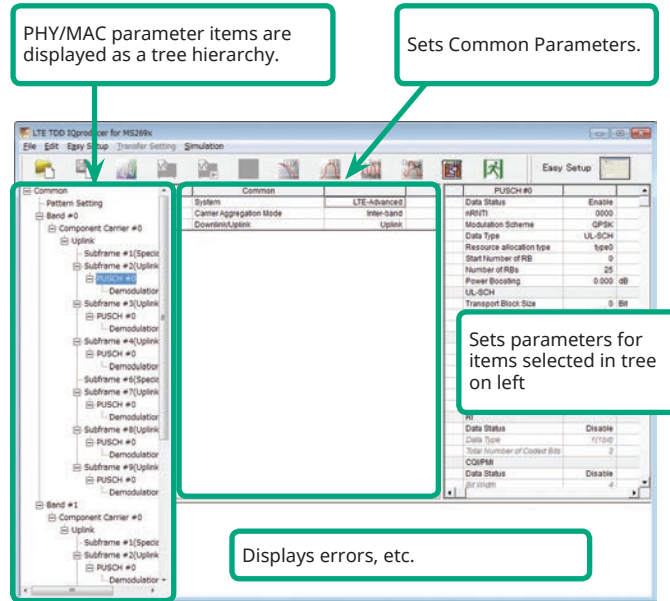

LTE-Advanced Setting Screen/Normal Setup Screen

Easy Setup Menu

3GPP-defined test conditions can be selected from the Easy Setup menu tree to set values for the Normal Setup screen parameters.

Example: E-UTRA Test Models

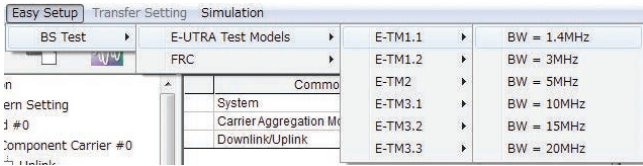

Simple operation by selecting target signals and component carriers as batch

Select Component Carrier Screen

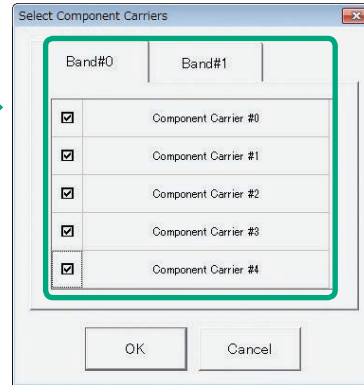

Example of Vector Signal Generator series LTE-Advanced Carrier Aggregation Function

Carrier Aggregation Mode	Vector Signal Generator Series	Vector Signal Generator		Vector Signal Generator Option for Signal Analyzer	
		MG3710A*1	MG3700A*1	MS2690A series Option 020	MS2830A Option 020/021
Intra-band contiguous Carrier Aggregation, Intra-band non-contiguous Carrier Aggregation		✓ (1 unit)	✓ (1 unit)	✓ (1 unit)	✓ (1 unit)
Inter-band non-contiguous Carrier Aggregation		✓ (2RF 1 unit*2, or 1RF 2 units)	✓ (2 units)	✓ (2 units)	✓ (2 units)

*1: LTE TDD IQproducer MX370110A and LTE-Advanced TDD Option MX370110A-001 installed.

*2: MG3710A-062 (2.7 GHz)/064 (4 GHz)/066 (6 GHz) 2ndRF Option installed.

Visual Check on Frame Structure Screen

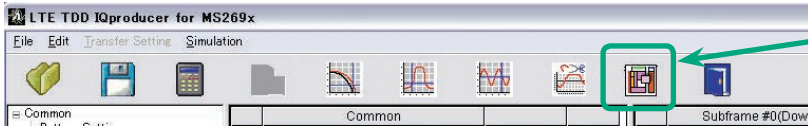

Displays Frame Structure screen for confirming channel allocation status and power of each OFDM Symbol

Power graph show/hide button

Full Scale button

Component Carrier select button

Band select button

Antenna Port select button

Display Resource Element allocation graphically with each channel color-coded.
Y-axis: Frequency (Resource Block units)
X-axis: Time (OFDM Symbol units)

Display power relative levels of OFDM Symbols with maximum power of 0 dB.
Y-axis: OFDM Symbol Power
X-axis: Time (OFDM Symbol units)

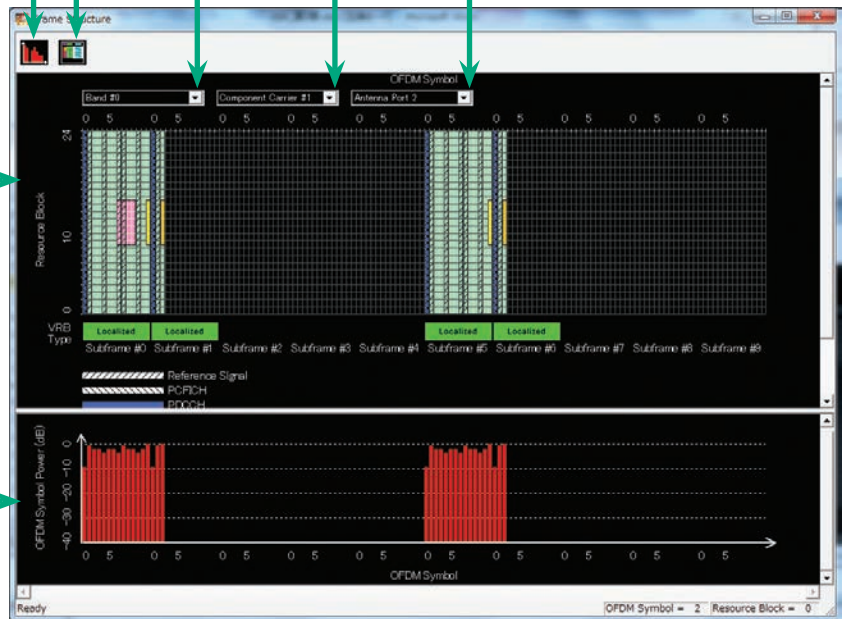

Frame Structure Screen (LTE-Advanced)

Optional

MS269xA

MS2830A

Easy Setup Screen Test Type Setting Range

Display	Outline	Setting Range
Test Type	Sets the Test Type.	E-UTRA Test Models, FRC (UL)

BS Test/E-UTRA Test Models Setting Range

Display	Outline	Setting Range
Common		
E-UTRA Test Models	Sets the E-UTRA Test Models.	E-TM1.1, E-TM1.2, E-TM2, E-TM2a, E-TM3.1, E-TM3.1a, E-TM3.2, E-TM3.3
Test Model Version	Sets the Test Model version of referred specifications.	3GPP TS 36.141 V8.2.0 (2009-03) 3GPP TS 36.141 V9.0.0 (2009-05)
Bandwidth	Sets the system bandwidth.	1.4, 3, 5, 10, 15, 20 MHz
Cell ID	Sets the Cell ID.	0 to 153
Uplink-downlink Configuration	Sets the Uplink-downlink Configuration.	3 fixed
Special Subframe Configuration	Sets the Special Subframe Configuration.	8 fixed
Roll Off Length	Sets the length of the ramp time applied to the OFDM symbol.	0 to 144
Filter	Sets filter.	Ideal, None

BS Test/FRC (UL) Setting Range

Display	Outline	Setting Range
Common		
FRC (UL)	Selects the setting items described in 3GPP TS 36.141 Annex A and automatically sets the parameters.	A1-1, A1-2, A1-3, A1-4, A1-5, A2-1, A2-2, A2-3
Bandwidth	Sets the system bandwidth.	The settable bandwidth changes according to the selected FRC (UL).
Cell ID	Sets the Cell ID.	0 to 503
Roll Off Length	Sets the length of the ramp time applied to the OFDM symbol.	0 to 144
Filter	Sets the filter type.	Ideal, None
Uplink-downlink configuration	Sets the Uplink-downlink Configuration.	0, 1, 2, 3, 4, 5, 6
Special Subframe Configuration	Sets the Special Subframe Configuration.	0 to 8
PUSCH		
Start Number of RB	Sets the start position of the RB to which the PUSCH is assigned.	Bandwidth = 1.4 MHz: 0 to (6-allocated resource block) Bandwidth = 3 MHz: 0 to (15-allocated resource block) Bandwidth = 5 MHz: 0 to (25-allocated resource block) Bandwidth = 10 MHz: 0 to (50-allocated resource block) Bandwidth = 15 MHz: 0 to (75-allocated resource block) Bandwidth = 20 MHz: 0 to (100-allocated resource block)
nRNTI	Sets the radio network temporary identifier.	0 to FFFF
Modulation	Sets the modulation mode.	QPSK, 16QAM, 64QAM
UL-SCH		
Transport Block Size	Sets the transport block size for UL-SCH.	0 to 86400
Data Type	Sets the Data type.	PN9fix, PN15fix, All0, All1
DMRS for PUSCH		
Group Hopping	Enables or disables group hopping.	Off, On
Sequence Hopping	Enables or disables Sequence Hopping.	Off, On
Delta ss	Sets Delta ss.	0 to 29
n(1)_DMRS	Sets the value used for automatic n_cs calculation.	0, 2, 3, 4, 6, 8, 9, 10
n(2)_DMRS	Sets the value used for automatic n_cs calculation.	0, 2, 3, 4, 6, 8, 9, 10

Easy Setup Screen (System = LTE-Advanced) Test Type Setting Range

Display	Outline	Setting Range
Test Type	Sets the Test Type	E-UTRA Test Models, FRC (UL)

BS Test/E-UTRA Test Models Setting Range

Display	Outline	Setting Range
E-UTRA Test Models	Sets the E-UTRA Test Models	E-TM1.1, E-TM1.2, E-TM2, E-TM2a, E-TM3.1, E-TM3.1a, E-TM3.2, E-TM3.3
Test Model Version	Sets the Test Model version of referred specifications.	3GPP TS 36.141 V8.2.0 (2009-03), 3GPP TS 36.141 V9.0.0 (2009-05)
Bandwidth	Sets the system bandwidth	1.4, 3, 5, 10, 15, 20 MHz
Cell ID	Sets the Cell ID	0 to 503
Uplink-downlink Configuration	Sets the Uplink-downlink configuration	When the Test Type is BS Test/E-UTRA Test Models, the setting is fixed to 3.
Special Subframe Configuration	Sets the Special Subframe configuration	When the Test Type is BS Test/E-UTRA Test Models, the setting is fixed to 8.
Roll Off Length	Sets the length of the ramp time applied to the OFDM symbol	0 to 144
Filter	Sets filter	Ideal, None

LTE TDD IQproducer MX269910A/LTE-Advanced TDD Option MX269910A-001

Optional

MS269xA

MS2830A

BS Test/FRC (UL) Setting Range

Display	Outline	Setting Range
Common		
FRC (UL)	Selects the setting items described in 3GPP TS 36.141 Annex A and automatically sets the parameters	A1-1, A1-2, A1-3, A1-4, A1-5, A2-1, A2-2, A2-3
Bandwidth	Sets the system bandwidth	The settable bandwidth changes according to the selected FRC (UL)
Cell ID	Sets the Cell ID	0 to 503
Roll Off Length	Sets the length of the ramp time applied to the OFDM symbol	0 to 144
Filter	Sets the filter type	Ideal, None
Uplink-downlink Configuration	Sets the Uplink-downlink configuration	0, 1, 2, 3, 4, 5, 6
Special Subframe Configuration	Sets the Special Subframe configuration	0 to 8
PUSCH		
Start Number of RB	Sets the start position of the RB to which the PUSCH is assigned	Bandwidth = 1.4 MHz: 0 to (6-allocated resource block) Bandwidth = 3 MHz: 0 to (15-allocated resource block) Bandwidth = 5 MHz: 0 to (25-allocated resource block) Bandwidth = 10 MHz: 0 to (50-allocated resource block) Bandwidth = 15 MHz: 0 to (75-allocated resource block) Bandwidth = 20 MHz: 0 to (100-allocated resource block)
nRNTI	Sets the radio network temporary identifier	0 to FFFF
Modulation	Sets the modulation mode	QPSK, 16QAM, 64QAM
UL-SCH		
Transport Block Size	Sets the transport block size for UL-SCH	0 to 86400
Data Type	Sets the Data type	PN9fix, PN15fix, All0, All1
DMRS for PUSCH		
Group Hopping	Enables or disables group hopping	Off, On
Sequence Hopping	Enables or disables Sequence Hopping	Off, On
Delta ss	Sets Delta ss	0 to 29
n(1)_DMRS	Sets the value used for automatic n_cs calculation	0, 2, 3, 4, 6, 8, 9, 10
n(2)_DMRS	Sets the value used for automatic n_cs calculation	0, 2, 3, 4, 6, 8, 9, 10

Carrier Aggregation Mode Setting Range

Display	Outline	Setting Range														
Carrier Aggregation Mode	Sets the Carrier Aggregation Mode	Intra-band, Inter-band														
Parameter																
Component Carrier	Displays the Component Carrier number	Display only														
Status	Enables or disables the Component Carrier parameter	Check box selected, or cleared														
Bandwidth	Displays the system bandwidth for the Component Carrier	Display only														
Cell ID	Displays the cell ID for the Component Carrier	Display only														
Gain	Sets the level ratio of Component Carrier	-80.00 to 0.00 [dB]														
Freq. Offset	Sets the frequency offset	0 to $\pm (0.4 \times F_s - 0.5 \times \text{Band})$ [MHz] Band: Changed depending on the Component Carrier# transmission system bandwidth (Bandwidth) <table border="1"> <thead> <tr> <th>Bandwidth [MHz]</th> <th>Band [MHz]</th> </tr> </thead> <tbody> <tr> <td>1.4</td> <td>1.095</td> </tr> <tr> <td>3.0</td> <td>2.715</td> </tr> <tr> <td>5.0</td> <td>4.515</td> </tr> <tr> <td>10.0</td> <td>9.015</td> </tr> <tr> <td>15.0</td> <td>13.515</td> </tr> <tr> <td>20.0</td> <td>18.015</td> </tr> </tbody> </table> Fs: 153.6 MHz (sampling rate)	Bandwidth [MHz]	Band [MHz]	1.4	1.095	3.0	2.715	5.0	4.515	10.0	9.015	15.0	13.515	20.0	18.015
Bandwidth [MHz]	Band [MHz]															
1.4	1.095															
3.0	2.715															
5.0	4.515															
10.0	9.015															
15.0	13.515															
20.0	18.015															
Phase	Sets the initial phase of the Component Carrier	0 to 359 [deg.]														
Delay	Sets delay of the Component Carrier	0 to 307200 [Ts]														
BS Test Type	Sets the details of BS Test Type of Component Carriers	BS Test/E-UTRA Test Models, BS Test/FRC(UL)														

Pattern Setting Setting Range

Display	Outline	Setting Range
Package	Enters waveform pattern package name	Up to 31 single-byte English alphanumeric characters
Export File Name	Enters waveform pattern file name	Carrier Aggregation Mode = Intra-band : Up to 18 single-byte English alphanumeric characters Carrier Aggregation Mode = Inter-band : Up to 15 single-byte English alphanumeric characters
Comment	Inputs comments to the waveform pattern	Up to 38 single-byte English alphanumeric characters \times 3 lines

LTE TDD IQproducer MX269910A/LTE-Advanced TDD Option MX269910A-001

Optional

MS269xA

MS2830A

Normal Setup Screen

Display	Outline	Setting Range
System	Switches 3GPP Systems	LTE, LTE-Advanced

Common Parameter Setting Range (System = LTE)

Display	Outline	Setting Range
Common		
Test Model	Sets test model	OFF, E-TM1.1, E-TM1.2, E-TM2, E-TM3.1, E-TM3.2, E-TM3.3
Test Model Version	Sets the Test Model version of referred specifications	3GPP TS 36.141 V8.2.0 (2009-03) 3GPP TS 36.141 V9.0.0 (2009-05)
Number of Antennas	Sets number of antennas	1, 2, 4 (2 and 4 only at Downlink)
Diversity Method	Sets diversity method	Spatial Multiplexing, Tx Diversity
Precoding Method	Sets precoding method	Without CDD, Large-delay CDD
Number of Layers	Sets number of layers	1, 2, 3, 4
Number of Code words	Sets number of code words	1, 2
Codebook Index	Sets codebook index	0 to 3 (When Number of Layers = 1) 0 to 2 (When Number of Layers = 2) 0 to 15 (When Number of Antennas = 4)
NID (1)	Sets physical-layer cell-identity group NID (1)	0 to 167
NID (2)	Sets physical-layer cell-identity group NID (2)	0, 1, 2
Cell ID	Sets cell ID	0 to 503
Number of Frames	Sets number of frames	1 to max. number of frames in memory
Oversampling Ratio	Sets over sampling ratio	2, 4
Sampling Rate	Displays sampling rate	1.92 × Over Sampling Ratio [MHz] (When Bandwidth = 1.4 MHz) 3.84 × Over Sampling Ratio [MHz] (When Bandwidth = 3 MHz) 7.68 × Over Sampling Ratio [MHz] (When Bandwidth = 5 MHz) 15.36 × Over Sampling Ratio [MHz] (When Bandwidth = 10 MHz) 15.36 × Over Sampling Ratio [MHz] (When Bandwidth = 15 MHz) 30.72 × Over Sampling Ratio [MHz] (When Bandwidth = 20 MHz)
Bandwidth	Sets system bandwidth	1.4, 3, 5, 10, 15, 20 MHz
Downlink/Uplink	Sets downlink/uplink settings	Downlink, Uplink
Uplink-downlink Configuration	Sets uplink-downlink Configuration	0, 1, 2, 3, 4, 5, 6
Special Subframe Configuration	Sets special subframe Configuration	0 to 8
Cyclic Prefix	Sets cyclic prefix	Normal, Extended
Subcarrier Spacing	Displays subcarrier spacing	15 kHz
Number of OFDM symbols per slot	Displays number of OFDM symbols per slot	7 Symbols (When Cyclic Prefix = Normal) 6 Symbols (When Cyclic Prefix = Extended)
Roll Off Length	Sets roll-off length for OFDM symbol	0 to 144 Ts (When Cyclic Prefix = Normal) 0 to 512 Ts (When Cyclic Prefix = Extended)
Filter		
Filter Type	Sets filter type	Nyquist, Root Nyquist, Ideal, None
Roll Off	Sets roll-off rate	0.1 to 1.0 (only enabled for Nyquist, Root Nyquist)

Common Parameter Setting Range (System = LTE-Advanced)

Display	Outline	Setting Range
Carrier Aggregation Mode	Sets the Carrier Aggregation Mode	Intra-band, Inter-band
Downlink/Uplink	Sets downlink or uplink	Downlink, Uplink

PHY/MAC Parameter Setting Range (LTE-Advanced)

Display	Outline	Setting Range														
Carrier Aggregation																
Component Carrier	Displays the Component Carrier number	0 to 4														
Status	Enables or disables the Component Carrier parameter	Check box selected, or cleared														
Bandwidth	Displays the system bandwidth for the Component Carrier	Display only														
Cell ID	Displays the Cell ID for the Component Carrier	Display only														
Gain	Sets the level ratio of Component Carrier	-80.00 to 0.00 [dB]														
Freq. Offset	Sets the frequency offset	0 to ± (0.4 × Fs - 0.5 × Band) [MHz] Band: Changed depending on the Component Carrier transmission system bandwidth (Bandwidth) <table border="1" style="margin-left: 20px;"> <thead> <tr> <th>Bandwidth [MHz]</th> <th>Band [MHz]</th> </tr> </thead> <tbody> <tr> <td>1.4</td> <td>1.095</td> </tr> <tr> <td>3.0</td> <td>2.715</td> </tr> <tr> <td>5.0</td> <td>4.515</td> </tr> <tr> <td>10.0</td> <td>9.015</td> </tr> <tr> <td>15.0</td> <td>13.515</td> </tr> <tr> <td>20.0</td> <td>18.015</td> </tr> </tbody> </table> Fs: 153.6 MHz (sampling rate)	Bandwidth [MHz]	Band [MHz]	1.4	1.095	3.0	2.715	5.0	4.515	10.0	9.015	15.0	13.515	20.0	18.015
Bandwidth [MHz]	Band [MHz]															
1.4	1.095															
3.0	2.715															
5.0	4.515															
10.0	9.015															
15.0	13.515															
20.0	18.015															
Phase	Sets the initial phase of the Component Carrier	0 to 359 [deg.]														
Delay	Sets delay of the Component Carrier	0 to 307200 [Ts]														

LTE TDD IQproducer MX269910A/LTE-Advanced TDD Option MX269910A-001

Optional

MS269xA

MS2830A

Display	Outline	Setting Range
Component Carrier		
Test Model	Sets the Test Model	OFF, E-TM1.1, E-TM1.2, E-TM2, E-TM3.1, E-TM3.2, E-TM3.3
Test Model Version	sets the Test Model version of referred specifications	3GPP TS 36.141 V8.2.0 (2009-03), 3GPP TS 36.141 V9.0.0 (2009-05)
Number of Antennas	Sets the number of antennas	1, 2, 4
Diversity Method	Sets the diversity method	Spatial Multiplexing, Tx Diversity
Precoding Method	Sets the precoding method	Without CDD, Large-delay CDD, Large-delay CDD (Cyclic Precoder Index)
Number of Layers	Sets the number of layers	1, 2, 3, 4
Number of Code words	Sets the number of code words	1, 2
Codebook index	Sets the codebook index	When Number of Antennas is 2, the setting range varies according to Number of Layers as follows Number of Layers is 1: 0 to 3 Number of Layers is 2: 0 to 2 When Number of Antennas is 4: 0 to 15
NID (1)	Sets the NID (1)	0 to 167
NID (2)	Sets the NID (2)	0, 1, 2
Cell ID	Sets the Cell ID	0 to 503
Number of Frames	Sets the number of frames to be generated	1 to the maximum number of frames that can be stored in the equipment's waveform memory
Over Sampling Ratio	Sets the oversampling ratio	1, 2, 4
Sampling Rate	Displays the sampling rate	Display only : It is automatically set according to the Oversampling Ratio and Bandwidth values
Bandwidth	Sets the system bandwidth	1.4, 3, 5, 10, 15, 20 MHz
Downlink/Uplink	Sets downlink or uplink	Downlink, Uplink
Uplink-downlink Configuration	Sets the Uplink-downlink Configuration	0, 1, 2, 3, 4, 5, 6
Special Subframe Configuration	Sets the Special Subframe Configuration	0 to 8
Cyclic Prefix	Sets the cyclic prefix	Normal, Extended
Subcarrier Spacing	Displays the subcarrier spacing (interval)	Display only
Number of OFDM symbols per slot	Sets the number of OFDM symbols per slot	Display only
Roll Off Length	Sets the length of the ramp time applied to the OFDM symbol	0 to 3152 Ts (in the case of Random Access Preamble) 0 to 144 Ts (when Cyclic prefix=Normal) 0 to 512 Ts (when Cyclic prefix=Extended) 432 Ts (in the case of PRACH)
Filter		
Filter Type	Sets the filter type	Nyquist, Root Nyquist, Ideal, None
Roll Off	Sets the roll-off factor	0.1 to 1.0

Pattern Setting Parameter Setting Range

Display	Outline	Setting Range
Reference signal		
Package	Set package name of waveform pattern	31 characters or less
Export File Name	Set pattern name of waveform pattern	18 characters or less
Line1	Set comment of waveform pattern	38 characters or less
Line2	Set comment of waveform pattern	38 characters or less
Line3	Set comment of waveform pattern	38 characters or less

Table 1

Subframe	UL/DL Configuration						
	0	1	2	3	4	5	6
0	D	D	D	D	D	D	D
1	S	S	S	S	S	S	S
2	U	U	U	U	U	U	U
3	U	U	D	U	U	D	U
4	U	D	D	U	D	D	U
5	D	D	D	D	D	D	D
6	S	S	S	D	D	D	S
7	U	U	U	D	D	D	U
8	U	U	D	D	D	D	U
9	U	D	D	D	D	D	D

Table 2

UL/DL Configuration	Subframe turned "off"
0	-
1	0, 5
2	0, 1, 4, 5, 6, 9
3	1, 5, 6, 7
4	0, 1, 4, 5, 6, 7
5	0, 1, 3, 4, 5, 6, 7, 9
6	-

Optional

MS269xA

MS2830A

PHY/MAC Parameter (Downlink) Setting Range

Display	Outline	Setting Range
Downlink		
PHICH duration	Sets the PHICH area.	Normal, Extended
Ng	Sets the parameter (Ng) for determining the PHICH arrangement.	1/6, 1/2
Reference Signal		
Frequency Shift Value	Displays frequency shift	0, 1, 2, 3, 4, 5
Power Boosting	Sets power boosting	-20.000 to +20.000 dB
PBCH		
Data Status	Enable/disables PBCH parameter	Disable, Enable
Data Type	Sets data type	PN9fix, PN15fix, 16bit repeat, User File, BCH
Data Type Repeat Data	Sets 16bit repeat data	0000 to FFFF (only when Data Type = 16bit repeat)
Data Type User File	Sets user file	Select any file (only when Data Type = User File)
Power Boosting	Sets power boosting	-20.000 to +20.000 dB
BCH		
Data Type	Sets data type	PN9fix, PN15fix, 16bit repeat, User File, BCCH
Data Type Repeat Data	Sets 16bit repeat data	0000 to FFFF (only when Data Type = 16bit repeat)
Data Type User File	Sets user file	Select any file (only when Data Type = User File)
Transport Block Size	Sets number of bits required for BCH	0 to 1920 bits (When Cyclic Prefix = Normal) 0 to 1728 bits (When Cyclic Prefix = Extended) When BCCH is selected for BCH Data Type, the setting is fixed to 24 bits.
DL Bandwidth	Displays data mapped to BCCH	n6 (When Bandwidth = 1.4 MHz) n15 (When Bandwidth = 3 MHz) n25 (When Bandwidth = 5 MHz) n50 (When Bandwidth = 10 MHz) n75 (When Bandwidth = 15 MHz) n100 (When Bandwidth = 20 MHz) This is only displayed when BCCH is selected for Data Type of BCH.
PHICH duration	Displays the PHICH duration mapped to BCCH	Normal, Extended This is only displayed when BCCH is selected for Data Type of BCH.
Ng	Displays the Ng value mapped to BCCH	1/6, 1/2, 1, 2 This is only displayed when BCCH is selected for Data Type of BCH.
Synchronization Signals		
Primary Synchronization Signal		
Data Status	Enable/disables primary synchronization signal parameter	Disable, Enable
Power Boosting	Sets power boosting	-20.000 to +20.000 dB
Secondary Synchronization Signal		
Data Status	Enable/disables secondary synchronization signal parameter	Disable, Enable
Power Boosting	Sets power boosting	-20.000 to +20.000 dB
Subframe #0 to #9		
Subframe Type	Display subframe type	<Table1> (Downlink, Uplink, Special)
Virtual Resource Block Type	Display virtual resource block type	Localized, Distributed
Gap	Sets Gap	1st Gap, 2nd Gap If Bandwidth is 1.4 MHz, 3 MHz, or 5 MHz, 1st Gap is displayed and Gap cannot be set. If Bandwidth is 10 MHz, 15 MHz, or 20 MHz, 1st Gap or 2nd Gap can be set.
Gap value	Displays Gap value	
Number of VRBs	Displays the number of VRB	
PHICH	Sets ON/OFF of PHICH	ON, OFF (Subframe in Table 2 is turned off by setting UL/DL Configuration)
Number of PHICH Groups	Displays number of PHICH groups in one subframe	
Number of OFDM symbols for PDCCH	Sets number of OFDM symbols for PDCCH	1 to 4 Symbol
Total Number of CCEs	Display total number of CCEs of control area in subframe	
Number of PDCCHs	Sets number of PDCCHs	1 to 64
CCE Arrangement	Sets CCE arrangement	PDCCH#0 to (Number of PDCCHs-1), dummy
Number of PDSCHs	Sets number of PDSCHs	1 to 64
RB Arrangement	Sets RB arrangement of PDSCH	PDSCH#0 to (Number of PDSCHs-1)
PCFICH		
Data Status	Enable/disables PCFICH parameter	Disable, Enable
Data Type	Sets data type	CFI codeword, PN9fix, PN15fix, 16bit repeat, User File
CFI	Sets CFI codeword type	1, 2, 3
Data Type Repeat Data	Sets 16bit repeat data	0000 to FFFF (only when Data Type = 16bit repeat)
Data Type User File	Sets user file	Select any file (only when Data Type = User File)
Power Boosting	Sets power boosting	-20.000 to +20.000 dB
PDCCH		
Data Status	Enable/disables PDCCH parameter	Disable, Enable
PDCCH format	Sets PDCCH format	0, 1, 2, 3
Data Type	Sets data type	PN9fix, PN15fix, 16bit repeat, User File, DCI
Data Type Repeat Data	Sets 16bit repeat data	0000 to FFFF (only when Data Type = 16bit repeat)
Data Type User File	Sets user file	Select any file (only when Data Type = User File)
Power Boosting	Set power boosting	-20.000 to +20.000 dB

LTE TDD IQproducer MX269910A/LTE-Advanced TDD Option MX269910A-001

Optional

MS269xA

MS2830A

Display	Outline	Setting Range
DCI		
Data Type	Sets data type	PN9fix, PN15fix, 16bit repeat, User File
Data Type Repeat Data	Sets 16bit repeat data	0000 to FFFF (only when Data Type = 16bit repeat)
Data Type User File	Sets user file	Select any file (only when Data Type = User File)
Transport Block Size	Sets number of bits required for DCI	0 to 576
nRNTI	Sets radio network temporary identifier	0000 to FFFF
PDSCH		
Data Status	Enable/disables PDSCH parameter	Disable, Enable
nRNTI	Sets radio network temporary identifier	0000 to FFFF
Modulation Scheme	Sets modulation scheme	QPSK, 16QAM, 64QAM, 256QAM
Data Type	Sets data type	PN9fix, PN15fix, 16bit repeat, User File, DL-SCH
Data Type Repeat Data	Sets 16bit repeat data	0000 to FFFF (only when Data Type = 16bit repeat)
Data Type User File	Sets user file	Select any file (only when Data Type = User File)
Power Boosting	Sets power boosting	-20.000 to +20.000 dB
DL-SCH		
Data Type	Sets data type	PN9fix, PN15fix, 16bit repeat, User File
Data Type Repeat Data	Sets 16bit repeat data	0000 to FFFF (only when Data Type = 16bit repeat)
Data Type User File	Sets user file	Select any file (only when Data Type = User File)
Transport Block Size	Sets number of bits required for DL-SCH	0 to 150000 bit
UE Category	Sets UE category	1, 2, 3, 4, 5
RV Index	Sets redundancy version index	0, 1, 2, 3
PHICH Group		
Data Status	Enable/disables PHICH parameter	Disable, Enable
Number of PHICHs	Sets number of PHICH	1 to 8 (Cyclic Prefix = Normal), 1 to 4 (Cyclic Prefix = Extended)
Power Boosting	Display power boosting of PHICH group	
PHICH #0 to # (Number of PHICHs-1)		
Data Status	Enable/disables PHICH parameter	Disable, Enable
Orthogonal Sequence Index	Sets orthogonal sequence index	0 to 7 (When Cyclic Prefix = Normal), 0 to 3 (When Cyclic Prefix = Extended)
Data Type	Display data type	HI
HI	Sets code word of HI (HARQ indicator)	000, 111
Power Boosting	Set power boosting	-20.000 to +20.000 dB

PHY/MAC Parameter (Uplink) Setting Range

Display	Outline	Setting Range
Uplink		
Data Transmission/PRACH	Selects Data Transmission or PRACH	Data Transmission, PRACH
DMRS Parameters	Sets the calculation method of Demodulation RS parameter.	Auto, Manual
PUCCH Parameters		
Delta PUCCH shift	Sets delta PUCCH shift	1, 2, 3
N_CS(1)	Sets number of cyclic shift for PUCCH format 1/1a/1b	0 to 7
N_RB(2)	Sets number of resource block for PUCCH format 2/2a/2b	0 to 63
Subframe #0 to #9		
Subframe Type	Display subframe type	<Table 1> (Downlink, Uplink, Special)
Number of PUCCHs	Sets number of PUCCHs	0 to 8
Number of PUSCHs	Sets number of PUSCHs	0 to 8
PUCCH #0 to #7		
Data Status	Enables/disables PUCCH parameter	Disable, Enable
n(1)_PUCCH	Sets resource number of PUCCH 1/1a/1b	0 to 764
n(2)_PUCCH	Sets resource number of PUCCH 2/2a/2b	0 to 764
nRNTI	Sets radio network temporary identifier	0000 to FFFF
PUCCH format	Sets PUCCH format	1, 1a, 1b, 2, 2a, 2b
Data Type	Sets data type	PN9fix, PN15fix, 16bit repeat, User File, UCI
Data Type Repeat Data	Sets 16bit repeat data	0000 to FFFF (only when Data Type = 16bit repeat)
Data Type User File	Sets user file	Select any file (only when Data Type = User File)
Group Hopping	Sets enable/disables	Disable, Enable
Base Sequence Group Number u	Sets base sequence group number	0 to 29 When Group Hopping is enabled this parameter becomes invalid and cannot be set. When DMRS Parameters is Auto, only calculated value displays and nothing can be set.
Base Sequence Number v	Displays base sequence number	0 fixed
Power Boosting	Sets power boosting	-20.000 to +20.000 dB

LTE TDD IQproducer MX269910A/LTE-Advanced TDD Option MX269910A-001

Optional

MS269xA

MS2830A

Display	Outline	Setting Range																					
UCI																							
Transport Block Size	Sets transport block size of UCI	1 (When PUCCH format = 1a) 2 (When PUCCH format = 1b) 1 to 13 (When PUCCH format = 2) 2 to 14 (When PUCCH format = 2a) 3 to 15 (When PUCCH format = 2b)																					
Data Type	Sets data type	PN9fix, PN15fix, 16bit repeat, User File																					
Data Type Repeat Data	Sets 16bit repeat data	0000 to FFFF (only when Data Type = 16bit repeat)																					
Data Type User File	Sets user file	Select any file (only when Data Type = User File)																					
Demodulation RS for PUCCH																							
Group Hopping	Sets enable/disables	Disable, Enable																					
Base Sequence Group Number u	Sets base sequence group number	0 to 29																					
Base Sequence Number v	Displays base sequence number	0 fixed																					
PUSCH #0 to #7																							
Data Status	Enables/disables PUSCH parameter	Disable, Enable																					
nRNTI	Sets radio network temporary identifier	0000 to FFFF																					
Modulation Scheme	Sets the modulation scheme	QPSK, 16QAM, 64QAM																					
Data Type	Sets data type	PN9fix, PN15fix, 16bit repeat, User File, UL-SCH																					
Data Type Repeat Data	Sets 16bit repeat data	0000 to FFFF (only when Data Type = 16bit repeat)																					
Data Type User File	Sets user file	Select any file (only when Data Type = User File)																					
Resource allocation type	Sets the Resource allocation type	type0, type1																					
Start Number of RB	Start position of RB	0 to 5 (When Bandwidth = 1.4 MHz) 0 to 14 (When Bandwidth = 3 MHz) 0 to 24 (When Bandwidth = 5 MHz) 0 to 49 (When Bandwidth = 10 MHz) 0 to 74 (When Bandwidth = 15 MHz) 0 to 99 (When Bandwidth = 20 MHz)																					
Number of RBs	Total number of RBs	1 to 6 (When Bandwidth = 1.4 MHz) 1 to 15 (When Bandwidth = 3 MHz) 1 to 25 (When Bandwidth = 5 MHz) 1 to 50 (When Bandwidth = 10 MHz) 1 to 75 (When Bandwidth = 15 MHz) 1 to 100 (When Bandwidth = 20 MHz)																					
Start Number of RBG for 1st	Sets the start position of the RBG for 1st	The setting range varies depending on the Bandwidth setting as follows <table border="1"> <thead> <tr> <th>Bandwidth (Number of RBs)</th> <th>Setting range*</th> </tr> </thead> <tbody> <tr> <td>1.4 MHz (6)</td> <td>1 to 4</td> </tr> <tr> <td>3 MHz (15)</td> <td>1 to 6</td> </tr> <tr> <td>5 MHz (25)</td> <td>1 to 11</td> </tr> <tr> <td>10 MHz (50)</td> <td>1 to 15</td> </tr> <tr> <td>15 MHz (75)</td> <td>1 to 17</td> </tr> <tr> <td>20 MHz (100)</td> <td>1 to 23</td> </tr> </tbody> </table> <p>*: The maximum value of the setting range is smaller than End Number of RBG for 1st + 1</p>	Bandwidth (Number of RBs)	Setting range*	1.4 MHz (6)	1 to 4	3 MHz (15)	1 to 6	5 MHz (25)	1 to 11	10 MHz (50)	1 to 15	15 MHz (75)	1 to 17	20 MHz (100)	1 to 23							
Bandwidth (Number of RBs)	Setting range*																						
1.4 MHz (6)	1 to 4																						
3 MHz (15)	1 to 6																						
5 MHz (25)	1 to 11																						
10 MHz (50)	1 to 15																						
15 MHz (75)	1 to 17																						
20 MHz (100)	1 to 23																						
End Number of RBG for 1st	Sets the end position of the RBG for 1st	The setting range varies depending on the Bandwidth setting as follows <table border="1"> <thead> <tr> <th>Bandwidth (Number of RBs)</th> <th>Setting range*</th> <th>Default</th> </tr> </thead> <tbody> <tr> <td>1.4 MHz (6)</td> <td>1 to 4</td> <td>3</td> </tr> <tr> <td>3 MHz (15)</td> <td>1 to 6</td> <td>3</td> </tr> <tr> <td>5 MHz (25)</td> <td>1 to 11</td> <td>6</td> </tr> <tr> <td>10 MHz (50)</td> <td>1 to 15</td> <td>8</td> </tr> <tr> <td>15 MHz (75)</td> <td>1 to 17</td> <td>8</td> </tr> <tr> <td>20 MHz (100)</td> <td>1 to 23</td> <td>12</td> </tr> </tbody> </table> <p>*: The maximum value of the setting range is smaller than End Number of RBG for 1st + 1</p>	Bandwidth (Number of RBs)	Setting range*	Default	1.4 MHz (6)	1 to 4	3	3 MHz (15)	1 to 6	3	5 MHz (25)	1 to 11	6	10 MHz (50)	1 to 15	8	15 MHz (75)	1 to 17	8	20 MHz (100)	1 to 23	12
Bandwidth (Number of RBs)	Setting range*	Default																					
1.4 MHz (6)	1 to 4	3																					
3 MHz (15)	1 to 6	3																					
5 MHz (25)	1 to 11	6																					
10 MHz (50)	1 to 15	8																					
15 MHz (75)	1 to 17	8																					
20 MHz (100)	1 to 23	12																					
Start Number of RBG for 2nd	Sets the start position of the RBG for 2nd	The setting range varies depending on the Bandwidth setting as follows <table border="1"> <thead> <tr> <th>Bandwidth (Number of RBs)</th> <th>Setting range*</th> <th>Default</th> </tr> </thead> <tbody> <tr> <td>1.4 MHz (6)</td> <td>3 to 6</td> <td>5</td> </tr> <tr> <td>3 MHz (15)</td> <td>3 to 8</td> <td>5</td> </tr> <tr> <td>5 MHz (25)</td> <td>3 to 13</td> <td>8</td> </tr> <tr> <td>10 MHz (50)</td> <td>3 to 17</td> <td>10</td> </tr> <tr> <td>15 MHz (75)</td> <td>3 to 19</td> <td>10</td> </tr> <tr> <td>20 MHz (100)</td> <td>3 to 25</td> <td>14</td> </tr> </tbody> </table> <p>*: The maximum value of the setting range is smaller than End Number of RBG for 1st + 1</p>	Bandwidth (Number of RBs)	Setting range*	Default	1.4 MHz (6)	3 to 6	5	3 MHz (15)	3 to 8	5	5 MHz (25)	3 to 13	8	10 MHz (50)	3 to 17	10	15 MHz (75)	3 to 19	10	20 MHz (100)	3 to 25	14
Bandwidth (Number of RBs)	Setting range*	Default																					
1.4 MHz (6)	3 to 6	5																					
3 MHz (15)	3 to 8	5																					
5 MHz (25)	3 to 13	8																					
10 MHz (50)	3 to 17	10																					
15 MHz (75)	3 to 19	10																					
20 MHz (100)	3 to 25	14																					
End Number of RBG for 2nd	Sets the end position of the RBG for 2nd	The setting range varies depending on the Bandwidth setting as follows <table border="1"> <thead> <tr> <th>Bandwidth (Number of RBs)</th> <th>Setting range</th> <th>Default</th> </tr> </thead> <tbody> <tr> <td>1.4 MHz (6)</td> <td>3 to 6</td> <td>6</td> </tr> <tr> <td>3 MHz (15)</td> <td>3 to 8</td> <td>8</td> </tr> <tr> <td>5 MHz (25)</td> <td>3 to 13</td> <td>13</td> </tr> <tr> <td>10 MHz (50)</td> <td>3 to 17</td> <td>17</td> </tr> <tr> <td>15 MHz (75)</td> <td>3 to 19</td> <td>19</td> </tr> <tr> <td>20 MHz (100)</td> <td>3 to 25</td> <td>25</td> </tr> </tbody> </table>	Bandwidth (Number of RBs)	Setting range	Default	1.4 MHz (6)	3 to 6	6	3 MHz (15)	3 to 8	8	5 MHz (25)	3 to 13	13	10 MHz (50)	3 to 17	17	15 MHz (75)	3 to 19	19	20 MHz (100)	3 to 25	25
Bandwidth (Number of RBs)	Setting range	Default																					
1.4 MHz (6)	3 to 6	6																					
3 MHz (15)	3 to 8	8																					
5 MHz (25)	3 to 13	13																					
10 MHz (50)	3 to 17	17																					
15 MHz (75)	3 to 19	19																					
20 MHz (100)	3 to 25	25																					
Power Boosting	Set power boosting	-20.000 to +20.000 dB																					

LTE TDD IQproducer MX269910A/LTE-Advanced TDD Option MX269910A-001

Optional

MS269xA

MS2830A

Display	Outline	Setting Range
UL-SCH		
Transport Block Size	Sets transport block size of UL-SCH	0 to 86400
Data Type	Sets data type	PN9fix, PN15fix, 16bit repeat, User File
Data Type Repeat Data	Sets 16bit repeat data	0000 to FFFF (only when Data Type = 16bit repeat)
Data Type User File	Sets user file	Select any file (only when Data Type = User File)
RV Index	Sets redundancy version index	0, 1, 2, 3
HARQ-ACK		
Data Status	This enables or disables HARQ-ACK	Disable, Enable
Data Type	Sets the Data type to be inserted into the HARQ-ACK	ACK, NACK, ACK-ACK, ACK-NACK, NACK-ACK, NACK-NACK
Total Number of Coded Bits	Sets the number of bits after HARQ-ACK encoding	0 to Number of RBs × 288
RI		
Data Status	Enables or disables the RI	Disable, Enable
Data Type	Sets the Data type to be inserted into the RI	1 (1 bit), 2 (1 bit), 1 (2 bits), 2 (2 bits), 3 (2 bits), 4 (2 bits)
Total Number of Coded Bits	Sets the number of bits after RI encoding	0 to Number of RBs × 288
CQI/PMI		
Data Status	Enables or disables the CQI/PMI	Disable, Enable
Data Type	Sets the Data type to be inserted into the CQI/PMI	PN9fix, PN15fix, 16bit repeat, User File
Data Type Repeat Data	Sets the 16bit repeat data to be inserted into the CQI/PMI	0000 to FFFF (only when Data Type = 16bit repeat)
Data Type User File	Sets the User type to be inserted into the CQI/PMI	Select any file (only when Data Type = User File)
Total Number of Coded Bits	Sets the number of bits after CQI/PMI encoding	0 to 86400
Demodulation RS for PUSCH		
Group Hopping	Sets enable/disables	Disable, Enable
Sequence Hopping	Sets enable/disables	Disable, Enable
Delta ss	Sets delta ss	0 to 29
Base Sequence Group Number u	Sets base sequence group number	0 to 29
Base Sequence Number v	Displays base sequence number	0, 1
Cyclic Shift 1st slot		
n_cs	Sets n_cs of first slot of demodulation RS	0 to 11
alpha	Sets cyclic shift of first slot of demodulation RS	Alpha is calculated by the following expression. Five digits below the decimal are displayed. $\alpha = 2 \times \pi \times n_cs / 12$
Cyclic Shift 2nd slot		
n_cs	Sets n_cs of second slot of demodulation RS	0 to 11
alpha	Sets cyclic shift of second slot of demodulation RS	Alpha is calculated by the following expression. Five digits below the decimal are displayed. $\alpha = 2 \times \pi \times n_cs / 12$
PRACH		
PRACH Configuration	Sets the transmission timing for PRACH	The settable values for PRACH Configuration are determined according to Uplink-downlink Configuration as the table below. However, the setup of PRACH Configuration from 48 to 57 is only available in the following conditions: Cyclic Prefix is Normal and Special Subframe Configuration is from 5 to 8, or Cyclic Prefix is Extended and Special Subframe Configuration is from 4 to 6.
Uplink-downlink Configuration	Settable values for PRACH Configuration	0 0 to 10, 12 to 18, 20 to 57 1 0 to 7, 9 to 12, 15 to 39, 48 to 57 2 0 to 4, 6, 9, 10, 12, 15, 16, 18, 48 to 57 3 0 to 9, 12 to 18, 20, 21, 23, 25 to 31, 33, 35 to 41, 43, 45 to 49, 51, 53 to 57 4 0 to 4, 6, 9, 10, 12, 15, 16, 18, 20, 21, 23, 25 to 31, 33, 35 to 39, 48, 49, 51, 53 to 57 5 0, 1, 3, 6, 9, 12, 15, 18, 48, 49, 51, 53 to 57 6 0 to 15, 18 to 41, 43, 45 to 57
Number of PRACH Resources	Displays the number of PRACH Resources	Depending on the PRACH Configuration
PRACH Resource #0 to #5		
Data Status	Enables or disables the PRACH Resource #	Disable, Enable
Preamble Format	Displays the Preamble Format which decides the length in the time axis of PRACH Resource #	Depending on the PRACH Configuration
Frequency Resource Index	Displays Frequency Resource Index which decides the position in the frequency axis of PRACH Resource #	Depending on the PRACH Configuration, Uplink-downlink Configuration, PRACH Resource#"
Transmit Frame	Displays Transmit Frame which decides the arrangement method of PRACH Resource# in the frame	Depending on the PRACH Configuration, Uplink-downlink Configuration, PRACH Resource#"
Subframe Number	Displays the subframe number that PRACH Resource# transmits	Depending on the PRACH Configuration, Uplink-downlink Configuration, PRACH Resource#"
Logical Root Sequence Number	Sets Logical Root Sequence Number that decides the value of Physical Root Sequence Number.	When Preamble Format is 0, 1, 2, 3: 0 to 837 When Preamble Format is 4: 0 to 137
Physical Root Sequence Number	Displays Physical Root Sequence Number used to calculate Cyclic Shift value	depending on the Logical Root Sequence Number
Cyclic Shift Set	Sets how to calculate Cyclic Shift value	Unrestricted, Restricted
v	Sets v value used to calculate Cyclic Shift value	0 to 63

Optional

MS269xA

MS2830A

Display	Outline	Setting Range
Zero Correlation Zone Config	Sets Zero Correlation Zone Config used to calculate Cyclic Shift value	When Preamble Format is 0, 1, 2, 3 and Cyclic Shift Set is Unrestricted: 0 to 15 When Preamble Format is 0, 1, 2, 3 and Cyclic Shift Set is Restricted: 0 to 14 When Preamble Format is 4: 0 to 6
Cyclic Shift Value	Displays the Cyclic Shift Value	depending on the Cyclic Shift Set, v, Zero Correlation Zone Config, Logical Root Sequence Number.
Frequency Offset	Sets the Frequency Offset of the PRACH Resource #	When Bandwidth is 1.4 MHz 0 When Bandwidth is 3 MHz 0 to 9 When Bandwidth is 5 MHz 0 to 19 When Bandwidth is 10 MHz 0 to 44 When Bandwidth is 15 MHz 0 to 69 When Bandwidth is 20 MHz 0 to 94
Initial Power Boosting	Sets the initial power of PRACH Resource #	-10.000 to 10.000 [dB]
Power Ramping Step Size	Sets the amount of power to be increased each time a PRACH is transmitted	-10.000 to 10.000 [dB]

Easy Setup Parameter Setting Range

Display	Setting Range
BS Test	
E-UTRA Test Models	E-TM1.1, E-TM1.2, E-TM2, E-TM2a, E-TM3.1, E-TM3.1a, E-TM3.2, E-TM3.3
FRC	FRC (QPSK, R = 1/3): A1-1, A1-2, A1-3, A1-4, A1-5 FRC (QPSK, R = 1/3): A3-1, A3-2, A3-3, A3-4, A3-5, A3-6, A3-7 FRC (16QAM, R = 2/3): A2-1, A2-2, A2-3 FRC (16QAM, R = 3/4): A4-1, A4-2, A4-3, A4-4, A4-5, A4-6, A4-7, A4-8 FRC (64QAM, R = 5/6): A5-1, A5-2, A5-3, A5-4, A5-5, A5-6, A5-7 FRC (Scenario 1): A7-1, A7-2, A7-3, A7-4, A7-5, A7-6 (except SRS Option) FRC (Scenario 2): A8-1, A8-2, A8-3, A8-4, A8-5, A8-6 (except SRS Option)

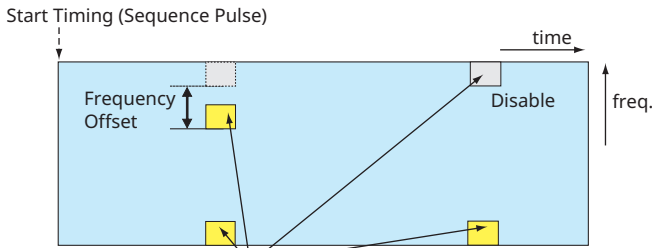

PRACH Configuration, Uplink-downlink Configuration
PRACH Parameters

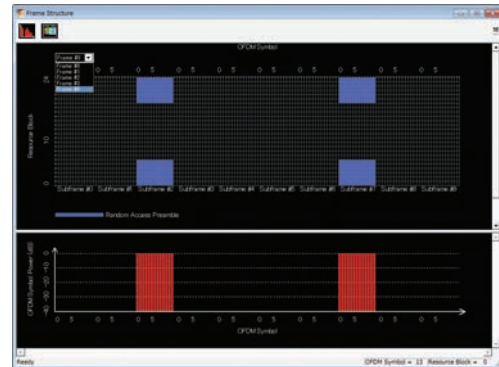

PRACH Parameter Settings
 Common - Downlink/Uplink: Uplink
 Uplink - Transmission Type: PRACH
 Uplink - Uplink-downlink Configuration: 2
 PRACH - Number of Frames: 5
 PRACH - PRACH Configuration: 12

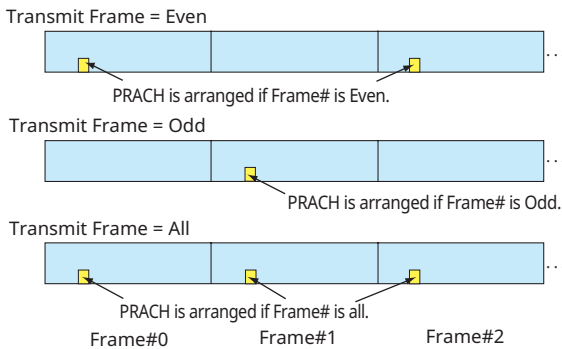

Configuration of PRACH Frame according to Transmit Frame

WLAN IQproducer MX269911A/802.11ac (80 MHz) Option MX269911A-001

Optional

MS269xA

MS2830A

The WLAN IQproducer MX269911A is PC application software with a GUI to generate IEEE Std 802.11-2007, IEEE Std 802.11n-2009 and IEEE 802.11ac compliant waveform patterns.

Installing the 802.11ac (80 MHz) option MX269911A-001 supports output of signals in compliance with IEEE 802.11ac standards.

WLAN IQproducer supports two setting screens: "Easy Setup Screen" and "Normal Setup Screen".

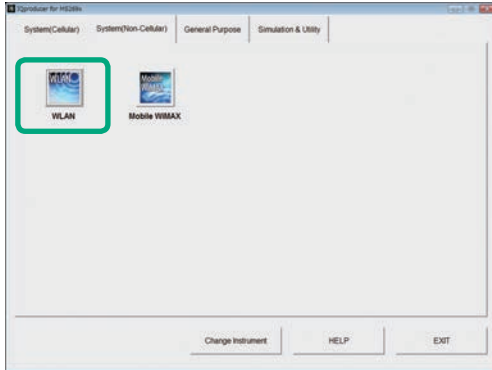

IQproducer Main Screen

Easy Setup Screen

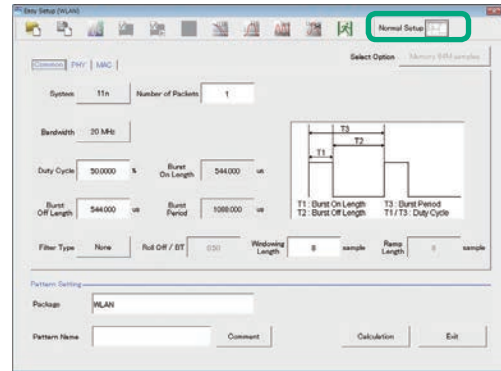

Normal Setup Screen

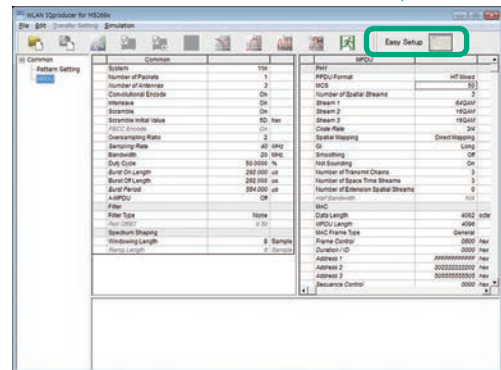

Sample Parameter File

MX269911A supports some sample parameter files. First, a sample parameter file is read (Recall), and detailed editing as necessary helps cut the parameter setting workload.

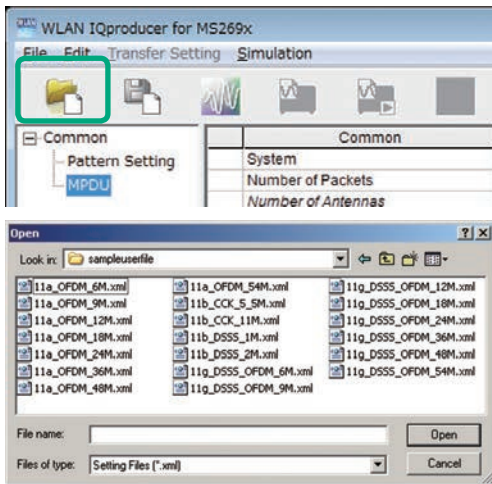

Parameter Recall Screen

Easy Setup Screen

Because it is limited to major parameters, it generates waveform patterns using simple operation. Use "Normal Setup function" for detailed parameter settings.

The screenshot shows the 'Easy Setup (WLAN)' interface. On the left, there are four sub-windows: 'System' (showing 11n selected), 'Bandwidth (System: 11n)' (showing 20 MHz selected), 'Bandwidth (System: 11ac)' (showing 80 MHz selected), and 'Filter Type' (showing None selected). The main window has several fields: 'System' (11n), 'Number of Packets' (1), 'Bandwidth' (20 MHz), 'Duty Cycle' (500000), 'Burst On Length' (544000 us), 'Burst Off Length' (544000 us), and a waveform diagram with T1, T2, and T3 labels. Callouts point to 'Number of Packets' (labeled 'Sets the number of packets to be generated') and the waveform diagram (labeled 'Sets burst On/Off ratio.').

Easy Setup Screen (Common Setup Screen)

Example: System: 11n, PDU Format: HT Mixed/HT Greenfield

The screenshot shows the PHY Setup Screen for System 11n. The 'PDU Format' is set to 'HT Mixed'. Other parameters include MCS (7), Number of Spatial Streams (1), Stream1 (64QAM), and Code Rate (5/6).

Example: System: 11n, PDU Format: Non-HT

The screenshot shows the PHY Setup Screen for System 11n with PDU Format set to 'Non-HT'. Parameters include Data Rate (54 Mbps), Modulation (64QAM), and Code Rate (3/4).

Example: System: 11a/11b/11g/11j/11p

The screenshot shows the PHY Setup Screen for System 11a/11b/11g/11j/11p. The 'System' is set to '11n'. Parameters include Data Rate (54 Mbps), Modulation (64QAM), High Rate Modulation (COOK), Code Rate (3/4), Preamble Type (Long), and Frame Format (ERP-OFDM).

Example: System: 11ac

The screenshot shows the PHY Setup Screen for System 11ac. The 'System' is set to '11n'. Parameters include PDU Format (VHT), MCS (8), Number of Spatial Streams (1), Modulation (256QAM), Code Rate (3/4), GI (Long), and Coding Mode (BCC).

Easy Setup Screen (PHY Setup Screen)

The screenshot shows the MAC Setup Screen. The 'MAC' tab is selected. Parameters include Data Length (4092 Octets), MPDU Length (4096 Octets), Increment Sequence Number (Off), Sequence Number Increment Period (1), and Increment Fragment Number (Off). The 'Mac Frame Format' section shows 'General' selected. The 'Mac Frame Format' table has columns for Frame Control, Duration/ID, Address 1, Address 2, Address 3, Seq Control, Address 4, QoS Control, HT Control, Frame Body, and FCS, with checkboxes for 'On' or 'Off'.

Easy Setup Screen (MAC Setup Screen)

WLAN IQproducer MX269911A/802.11ac (80 MHz) Option MX269911A-001

Optional

MS269xA

MS2830A

Normal Setup Screen (IEEE 802.11n/p/a/b/g/j)

Sets system, number of packets in one waveform pattern, On/Off ratio (Duty) and filter at Common sheet.

The screenshot shows the 'WLAN IQproducer for MS269xA' software interface. It features a tree view on the left with 'Common' and 'MPDU' selected. The main area is divided into two columns: 'Common' and 'MPDU'. The 'Common' column contains system-level parameters, while the 'MPDU' column contains PHY and MAC parameters. Callouts provide detailed explanations for these sections.

Parameters displayed as tree. Add and delete A-MPDU.
 Pattern Setting, MPDU, A-MPDU

PHY/MAC parameter part displays selected MPDU and A-MPDU as tree.

All PHY parameters are the same value with MPDU and A-MPDU.
 Sets PPDU format, MCS, modulation method and data rate.

Common sets parameters, such as system, bandwidth, On/Off ratio, and filter.

MAC parameter supports different settings with MPDU and A-MPDU.
 Sets data length, MAC frame, address, etc.

Common		MPDU	
System	11n	PHY	
Number of Packets	1	PPDU Format	HT Mixed
Number of Antennas	3	MCS	50
Convolutional Encode	On	Number of Spatial Streams	3
Interleave	On	Stream 1	64QAM
Scramble	On	Stream 2	16QAM
Scramble Initial Value	5D hex	Stream 3	16QAM
PBCC Encode	On	Code Rate	3/4
Oversampling Ratio	2	Spatial Mapping	Direct Mapping
Sampling Rate	40 MHz	GI	Long
Bandwidth	20 MHz	Smoothing	Off
Duty Cycle	50.0000 %	Not Sounding	On
Burst On Length	292.000 us	Number of Transmit Chains	3
Burst Off Length	292.000 us	Number of Space Time Streams	3
Burst Period	584.000 us	Number of Extension Spatial Streams	0
A-MPDU	Off	Half Bandwidth	N/A
Filter		MAC	
Filter Type	None	Data Length	4082 octe
Roll Off BT	0.50	MPDU Length	4096
Spectrum Shaping		MAC Frame Type	General
Windowing Length	8 Sample	Frame Control	0000 hex
Ramp Length	8 Sample	Duration / ID	0000 hex
		Address 1	FFFFFFFF hex
		Address 2	2022222202 hex
		Address 3	5055555505 hex
		Sequence Control	0000 hex

WLAN IQproducer Setting Screen

Optional

MS269xA

MS2830A

System Setting

Selects and sets System.

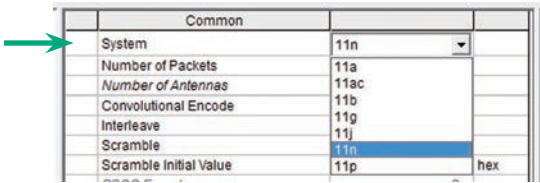

Duty Cycle Setting

Sets burst On/Off ratio according to Rx test conditions. Sets Duty Cycle and Burst Off Length. Burst On Length is decided by Data Length settings of MAC parameter. Burst Period is decided by Duty Cycle and Burst Off Length settings.

Duty Cycle	50.0000	%
Burst On Length	544.000	us
Burst Off Length	544.000	us
Burst Period	1088.000	us

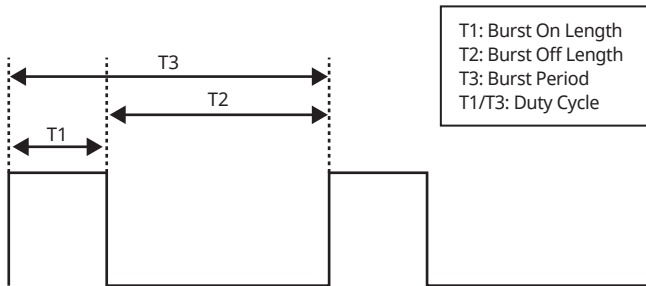

Burst On/Off Setting Image

MAC Frame Type Selection

Clicking MAC Frame Type "General" displays MAC Frame format setting screen to set address information. Match address of Rx equipment for Rx tests.

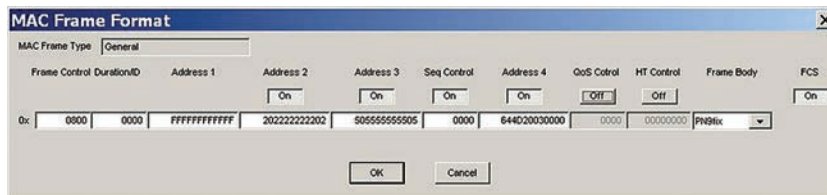
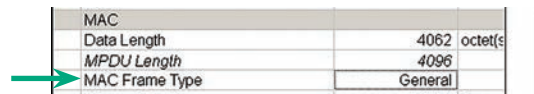

PPDU Format Selection for IEEE 802.11n Signals

Selects and sets following for IEEE 802.11n signals:

- PPDU format: Non-HT, HT Mixed, HT Greenfield
- MCS: 0 to 76

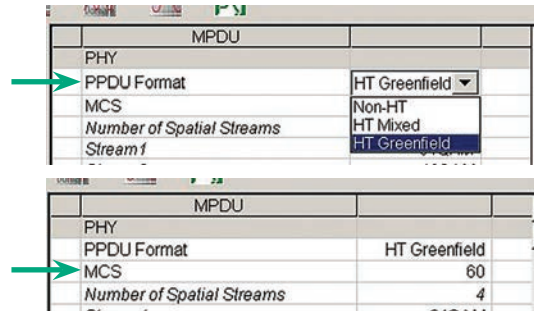

Filter Selection

Sets waveform pattern filter conditions for system or Rx specifications.

- None, Gaussian, Root Nyquist, Nyquist, Ideal

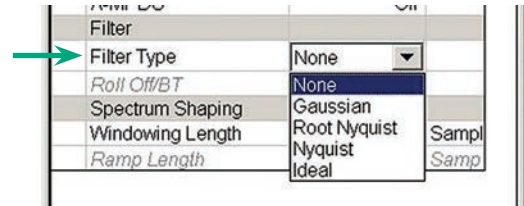

Increment Selection

Select On/Off matching Rx test conditions.

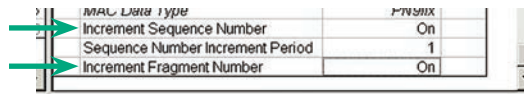

WLAN IQproducer MX269911A/802.11ac (80 MHz) Option MX269911A-001

Optional

MS269xA

MS2830A

Normal Setup Screen (IEEE 802.11ac)

This screen sets common settings, such as user mode (Single User/ Multi User), bandwidth, number of packets in one waveform pattern, On/Off ratio (Duty), filter, and PHY/MAC parameters.

Displays MPDU/ A-MPDU in tree for each user #. User/ MPDU/A-MPDU can be added and deleted. Pattern Setting, User #0 to #3 MPDU, A-MPDU.

Common sets parameters, such as User Mode (Single User/Multi User), bandwidth, On/Off ratio, and filter.

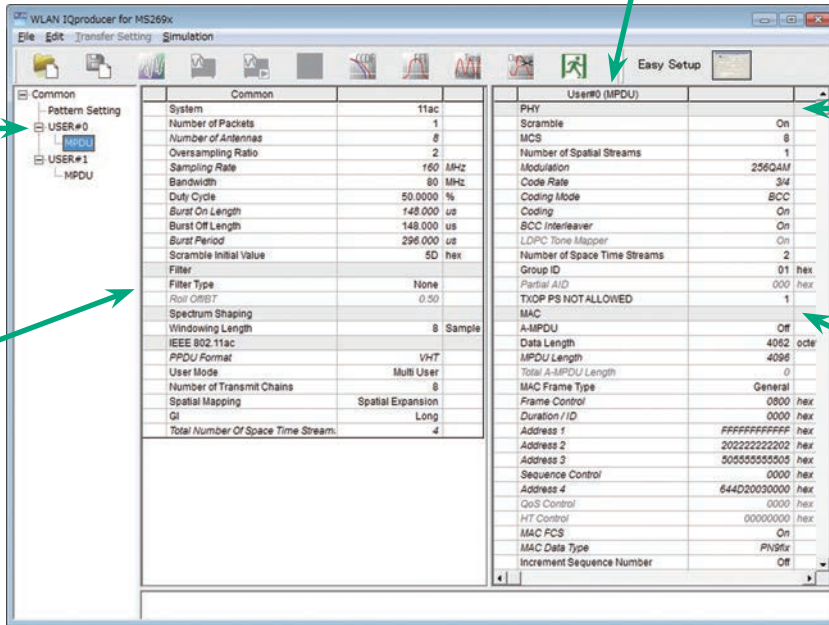

Displays MPDU and A-MPDU for selected user# for PHY/MAC parameter.

Each user# PHY parameter becomes same value at all MPDU, and A-MPDU. Sets MCS, modulation method, etc.

Different value can be set for each user# MAC parameter at MPDU, A-MPDU. Sets data length, MAC frame, address, etc.

Selects Bandwidth

Selects and sets following
20 MHz, 40 MHz, 80 MHz, 80 + 80 MHz

Bandwidth	80	MHz
Duty Cycle	20	%
Burst On Length	40	us
Burst Off Length	80	us
Burst Period	80+80	us

PPDU format

Fixes PPDU format to "VHT"

IEEE 802.11ac	VHT
PPDU Format	VHT

Selects User Mode

Selects and sets Single User / Multi User.
Sets up to four users from #0 to #3 at Multi User setting.

IEEE 802.11ac	VHT
PPDU Format	VHT
User Mode	Multi User
Number of Transmit Chains	Single User
Spatial Mapping	Multi User

Sets Number of Transmit Chain

Setting range: 1 to 8

IEEE 802.11ac	VHT
PPDU Format	VHT
User Mode	Multi User
Number of Transmit Chains	8

Sets MCS

Setting range: 0 to 9

Sets modulation method according to MCS setting.

PHY	On
Scramble	On
MCS	8
Number of Spatial Streams	1
Modulation	256QAM
Code Rate	3/4

Supported Vector Signal Generator Series IEEE 802.11ac Signal bandwidth

IEEE 802.11ac Signal Bandwidth	Vector Signal Generator		Vector Signal Generator Option for Signal Analyzer	
	MG3710A*1	MG3700A*2	MS2690A series Option 020*3	MS2830A Option 020/021*3
20 MHz/40 MHz/80 MHz	✓ (1 unit)	✓ (1 unit)	✓ (1 unit)	✓ (1 unit)
160 MHz	✓ (1 unit)	—	—	—
80 MHz + 80 MHz (non-contiguous)	✓ (2RF 1 unit*4, or 1RF 2 units)	✓ (2 units)	✓ (2 units)	✓ (2 units)

*1: WLAN IQproducer MX370111A and 802.11ac (160 MHz) Option MX370111A-002 installed.

*2: WLAN IQproducer MX370111A and 802.11ac (80 MHz) Option MX370111A-001 installed.

*3: WLAN IQproducer MX269911A and 802.11ac (80 MHz) Option MX269911A-001 installed.

*4: MG3710A-062 (2.7 GHz)/064 (4 GHz)/066 (6 GHz) 2ndRF Option installed.

WLAN IQproducer MX269911A/802.11ac (80 MHz) Option MX269911A-001

Optional

MS269xA

MS2830A

Easy Setup Screen

Common Parameter Setting Range

Display	Outline	Setting Range
Common		
System	Sets the system	11a, 11ac, 11b, 11g, 11j, 11n, 11p
Number of Packets	Sets the number of packets to be generated	1 to the maximum number of packets for the waveform memory
Bandwidth	Sets the bandwidth	System = 11a/11j: 20 MHz System = 11n: 20 MHz or 40 MHz System = 11p: 10 MHz System = 11ac: 20, 40, 80, 80 + 80 MHz Not available when System = 11b, 11g
Duty Cycle	Sets the On/Off ratio of the burst signal	0.1000 to 99.0000 [%] When setting Duty Cycle, Burst Off Length and Burst Period are automatically calculated. Also, when Burst On Length or Burst Off Length is changed, Duty Cycle is automatically calculated
Burst On Length	Displays the burst on length [us]	Displays the calculated value The calculated result is rounded to a multiple of 1/Sampling Rate [μs]
Burst Off Length	Sets the burst off length [us]	The setting range is decided by the maximum and minimum values of Duty Cycle and the calculated value of Burst On Length
Burst Period	Display the burst period [us]	Displays the calculated value
Filter Type	Sets the filter type	None, Gaussian, Root Nyquist, Nyquist, Ideal
Roll Off/BT	Sets the roll-off factor or BT product	0.1 to 1.00 (The setting is fixed when Filter Type is set to Ideal or None)
Windowing Length	Sets the windowing length	0 to 32 × Oversampling Rate: Available in the following conditions: System = 11a, 11j, 11p, 11n, 11ac System = 11g, and Frame Format = ERP-OFDM, DSSS-OFDM
Ramp Length	Sets the ramp length	0 to 16 × Oversampling Rate: Available in the following conditions: System = 11b System = 11g, and Frame Format = ERP-DSSS, ERP-CCK, ERP-PBCC

PHY Parameter Setting Range

Display	Outline	Setting Range
PPDU Format	Sets the PPDU Format	System = 11n: Non-HT, HT-Mixed, and HT-Greenfield System = 11ac: VHT
MCS	Sets the MCS	System = 11n: 0 to 7 System = 11ac: 0 to 9 Available in the following conditions: System = 11n, and PPDU Format = HT Mixed, or HT Greenfield, or System = 11ac
Number of Spatial Streams	Sets the number of streams	
Data Rate	Sets the data rate	1, 2, 3, 4.5, 5.5, 6, 9, 11, 12, 18, 22, 24, 27, 33, 36, 48, 54 Not available in the following conditions: System = 11n, and PPDU Format = HT Mixed or HT Greenfield, or System = 11ac
Modulation	Displays the PSDU modulation method	BPSK, QPSK, 16QAM, 64QAM, DBPSK, DQPSK: Not available in the following conditions: System = 11b and Data Rate = 5.5, 11 Mbps System = 11g and Data Rate = 5.5, 11, 22, 33 Mbps System = 11n and PPDU Format = HT Mixed or HT Greenfield
High Rate Modulation	Sets the modulation method for direct sequence spread spectrum	CCK, PBCC: Available in the following conditions: System = 11b System = 11g and Frame Format = ERP-CCK, ERP-PBCC CCK, PBCC is selectable when Data Rate = 5.5 Mbps, 11 Mbps Only PBCC can be set when Data Rate = 22 Mbps, 33 Mbps
Code Rate	Displays the coding rate	1/2, 2/3, 3/4, 5/6 Not available in the following conditions: System = 11b System = 11g, and Data Rate = 1, 2, 5.5, 11, 22, 33 Mbps.
Preamble Type	Sets the preamble type	Long, Short: Available in the following conditions: System = 11b, System = 11g (Only Long can be set when System = 11g, Frame Format = ERP-DSSS, Data Rate = 1 Mbps) (Only Long can be set when System = 11g, and Frame Format = ERP-OFDM) (Only Long can be set when System = 11b, and Data Rate = 1 Mbps)
Frame Format	Sets the secondary modulation method for header and payload	ERP-OFDM, DSSS-OFDM, ERP-DSSS, ERP-CCK, ERP-PBCC: Available in the following conditions: System = 11g
GI	Sets the guard interval length	Short, Long: Available in the following conditions: System = 11n and PPDU Format = HT Mixed, or HT Greenfield or System = 11ac
Coding Mode	Sets the coding mode	This function can be set in the following cases: System = 11ac

WLAN IQproducer MX269911A/802.11ac (80 MHz) Option MX269911A-001

Optional

MS269xA

MS2830A

MAC Parameter Setting Range

Display	Outline	Setting Range
Data Length	Sets the data length	System = 11a, 11b, 11g, 11j, 11p, or System = 11n and PPDU format = Non-HT: 1 to (4095-Diff) System = 11n, and PPDU Format = HT Mixed, or HT Greenfield: 1 to (65535-Diff) System = 11ac: 1 to (65535-Diff) Diff = Total Length (Mac Header + FCS) - (Sum of the MAC parameters set to Off in the Frame Format setting screen [octet(s)]) Total Length = 40 [octet(s)]
MPDU Length	Displays the MPDU length	System = 11a, 11b, 11g, 11j, 11p, or System = 11n and PPDU format = Non-HT: (Diff + 1) to 4095 System = 11n, and PPDU Format = HT Mixed, or HT Greenfield: (Diff+1) to 65535 System = 11n, and A-MPDU = ON: (Diff + 1) to 4095 System = 11ac: (Diff+1) to 65535 [octet(s)]
MAC Data Type	Sets the type of data assigned to the MAC frame body	PN9fix, PN15fix, 16bit repeat, User File
Frame Control	Sets the frame control	0x0000 to 0xFFFF
Duration/ID	Sets the Duration/ID	0x0000 to 0xFFFF
Address1/2/3/4	Sets the MAC Address1/2/3/4	0x0000 0000 0000 to 0xFFFF FFFF FFFF
Sequence Control	Sets the Sequence Control	0x0000 to 0xFFFF
QoS Control	Sets the QoS Control	0x0000 to 0xFFFF
HT Control	Sets the HT Control	0x0000 0000 to 0xFFFF FFFF
Increment Sequence Number	Sets whether to increment the sequence number	On, Off If set to On, the count-up operation starts from the upper 12 bits of the value specified for Sequence Control, incrementally at each interval specified by Sequence Number Increment Period
Sequence Number Increment Period	Sets the interval to increment the sequence number	1 to 15: This is available when Increment Sequence Number is set to On
Increment Fragment Number	Sets whether to increment the Fragment Number	On, Off If set to On, the count-up operation starts from the lower 4 bits of the value specified for Sequence Control, incrementally for each frame at each interval specified by Sequence Number Increment Period
FCS	Sets whether to enable the MAC checksum function	On, Off

Normal Setup Screen

Common Parameter Setting Range

Display	Outline	Setting Range
Common		
System	Sets System standard	11a, 11ac, 11b, 11g, 11j, 11n, 11p

Common Parameter Setting Range (System = other than 11ac)

Display	Outline	Setting Range
Common		
Number of Packets	Sets the number of packets to be generated	1 to the maximum capacity of waveform memory
Number of Antennas	Displays the number of antennas	1 to 4: Displays the value of Number of Transmit Chains in the following conditions: System = 11n, and PPDU Format = HT Mixed, or HT Greenfield The setting is fixed to 1 when the System is other than 11n.
Convolutional Encode	Enables/Disables convolutional encoding	On, Off
Interleave	Enables/Disables interleave processing	On, Off: This is available in the following conditions: System = 11a, 11j, 11n, 11p, System = 11g, and Frame Format = DSSS-OFDM/ERP-OFDM
Scramble	Enables/Disables scramble processing	On, Off
Scramble Initial Value	Sets the initial value of scramble processing	0x00 to 0x7F: Available only for System = 11a, 11n
PBCC Encode	Enables/Disables PBCC encoding	On, Off: This is available in the following conditions: System = 11b and High Rate Modulation = PBCC System = 11g and Frame Format = ERP-PBCC
Oversampling Ratio	Sets oversampling ratio	The setting range for each system is as follows: System = 11b: 4, 8 System = 11a, 11g, 11j, 11n, 11p : 2, 4, 8 System = 11g, Data Rate = 1, 2, 5.5, 11, 22, 33 Mbps : 4, 8 Note, however, that the setting range is 2 and 4 if System = 11n and Bandwidth = 40 MHz
Sampling Rate	Displays the sampling rate	System = 11a: 20 MHz × Oversampling Ratio System = 11b: 11 MHz × Oversampling Ratio System = 11g, Data Rate = 1, 2, 5.5, 11 Mbps: 11 MHz × Oversampling Ratio System = 11g, Data Rate = other than 1, 2, 5.5, 11 Mbps: 20 MHz × Oversampling Ratio System = 11j: 20 MHz × Oversampling Ratio System = 11n, Bandwidth = 20 MHz: 20 MHz × Oversampling Ratio System = 11n, Bandwidth = 40 MHz: 40 MHz × Oversampling Ratio System = 11p: 10 MHz × Oversampling Ratio
Bandwidth	Set bandwidth	System = 11p: 10 MHz System = 11a/11j: 20 MHz System = 11n: 20 MHz or 40 MHz Not available when System = 11b, 11g

WLAN IQproducer MX269911A/802.11ac (80 MHz) Option MX269911A-001

Optional

MS269xA

MS2830A

Display	Outline	Setting Range
Duty Cycle	Sets the On/Off ratio of the burst signal	0.1000 to 99.0000% When Duty Cycle is set, Burst Off Length and Burst Period is automatically calculated. When Burst On Length and Burst Off Length is changed, Duty Cycle is automatically calculated
Burst On Length	Displays Burst On Length [μs]	Displays the calculated value. The calculated result is rounded to a multiple of 1/Sampling Rate [μs]
Burst Off Length	Displays Burst Off Length [μs]	The setting range is decided by the maximum and minimum values of Duty Cycle and the calculated value of Burst On Length. When setting Burst Off Length, Duty Cycle and Burst Period are automatically calculated. Also, Burst Off Length is calculated from the values of Duty Cycle and Burst On Length as below. Burst Off Length = Burst On Length × (100.0 - Duty Cycle)/Duty Cycle
Burst Period	Displays Burst Period [μs]	Displays the calculated value
A-MPDU	Enables/Disables A-MPDU	On, Off: Available in the following conditions: System = 11n and PPDU Format = HT Mixed, or HT Greenfield
Filter		
Filter Type	Sets the filter type	None, Gaussian, Root Nyquist, Nyquist, Ideal
Roll Off/BT	Sets the roll-off factor or BT product	0.01 to 1.00 (The setting is not available when Filter Type is set to Ideal or None)
Spectrum Shaping		
Windowing Length	Sets the windowing length	0 to 32 × Oversampling Rate: Available in the following conditions: System = 11a, 11j, 11p, 11n System = 11g, and when Frame Format is ERP-OFDM/DSSS-OFDM
Ramp Length	Sets the ramp length	0 to 16 × Oversampling Rate: Available in the following conditions: System = 11b System = 11g, and when Frame Format is ERP-DSSS/ERP-CCK/ERP-PBCC

Common Parameter Setting Range (System = 11ac)

Display	Outline	Setting Range
Common		
Number of Packets	Sets the number of packets to be generated	1 to the maximum capacity of waveform memory
Number of Antennas	Displays the number of antennas	1 to 8
Oversampling Ratio	Sets the oversampling ratio	2, 4, 8 Bandwidth = 40 MHz: 2, 4 Bandwidth = 80 MHz/80 + 80 MHz: 2 only.
Sampling Rate	Displays sampling rate	Bandwidth MHz × Oversampling Ratio
Bandwidth	Sets the bandwidth	20, 40, 80, 80 + 80 MHz
Duty Cycle	Sets the On/Off ratio of the burst signal	0.1000 to 99.0000 [%] When setting Duty Cycle, Burst Off Length and Burst Period are automatically calculated. Also, when Burst On Length or Burst Off Length is changed, Duty Cycle is automatically calculated
Burst On Length	Displays Burst On Length [μs]	Displays the calculated value (The calculated result is rounded to a multiple of 1/Sampling Rate [μs])
Burst Off Length	Displays Burst Off Length [μs]	The setting range is decided by the maximum and minimum values of Duty Cycle and the calculated value of Burst On Length. When setting Burst Off Length, Duty Cycle and Burst Period are automatically calculated. Also, Burst Off Length is calculated from the values of Duty Cycle and Burst On Length as below. Burst Off Length = Burst On Length × (100.0 - Duty Cycle)/Duty Cycle
Burst Period	Displays the burst period [μs]	Displays the calculated value
Scramble Initial Value	Sets the initial value of scramble processing	0x00 to 0x7F
Filter		
Filter Type	Sets the filter type	None, Gaussian, Root Nyquist, Nyquist, Ideal
Roll Off/BT	Sets the roll-off factor or BT product	0.01 to 1.00 (The setting is not available when Filter Type is set to Ideal or None)
Spectrum Shaping		
Windowing Length	Sets the windowing length	0 to 32 × Oversampling Rate
IEEE 802.11ac		
PPDU Format	Displays the PPDU format	VHT
User Mode	Sets the user mode	Single User, Multi User
Number of Transmit Chains	Sets the number of transmit chain	1 to 8 Number of Transmit Chains cannot be set to equal to or under Total Number of Space Time Streams
Spatial Mapping	Sets the spatial mapping	Direct Mapping, Spatial Expansion, Edit Mode This function can be used in the following cases: Direct Mapping is available only when Number of Space Time Streams matches Number of Transmit Chains. When Number of Transmit Chains is 1, only Direct Mapping is available
Edit Mode	Sets the value of Spatial Mapping Matrix	-1.00000 - j1.00000 to 1.00000 + j1.00000 The setting resolution is 0.00001 for both real and imaginary parts
Spatial Mapping Matrix	Sets the Spatial Mapping	Number of Transmit Chains: 1 to 8 Total Number of Space Time Streams: 1 to 8
GI	Sets the guard interval	Short, Long
Total Number of Space Time Streams	Displays the total number of space time stream	1 to 8 Displays the total number of space time streams under each User#

WLAN IQproducer MX269911A/802.11ac (80 MHz) Option MX269911A-001

Optional

MS269xA

MS2830A

PHY Parameter Setting Range (System = other than 11ac)

Display	Outline	Setting Range
PPDU Format	Sets the PPDU format	Non-HT, HT Mixed, HT Greenfield: Available in the following conditions: System = 11n
MCS	Sets the MCS	0 to 76: Available in the following conditions: System = 11n and PPDU Format = HT Mixed, or HT Greenfield Details about the parameters when MCS is set are defined in IEEE Std 802.11n-2009 20.6
Number of Spatial Streams	Displays the number of spatial streams	1 to 4: Available in the following conditions: System = 11n and PPDU Format = HT Mixed, or HT Greenfield The displayed value varies according to MCS
High Rate Modulation	Sets the modulation scheme during direct diffusion	CCK, PBCC: Available in the following conditions: System = 11b System = 11g, and Frame Format = ERP-CCK, ERP-PBCC CCK, PBCC is selectable when Data Rate = 5.5 Mbps, 11 Mbps. Only PBCC can be set when Data Rate = 22 Mbps, 33 Mbps
Modulation	Displays the PSDU modulation scheme	BPSK, QPSK, 16QAM, 64QAM, DBPSK, DQPSK: Not available in the following conditions: System = 11b and Data Rate = 5.5, 11 Mbps System = 11g and Data Rate = 5.5, 11, 22, 33 Mbps System = 11n and PPDU Format = HT Mixed, or HT Greenfield
Code Rate	Displays the code rate	1/2, 2/3, 3/4, 5/6 System = 11b System = 11g, and Data Rate = 1, 2, 5.5, 11, 22, 33 Mbps. Display only when System = 11n and PPDU Format = HT Mixed, or HT Greenfield
Data Rate	Sets the data rate	1, 2, 3, 4.5, 5.5, 6, 9, 11, 12, 18, 22, 24, 27, 33, 36, 48, 54 This setting is not available in the following conditions: System = 11n and PPDU Format = HT Mixed, or HT Greenfield
Preamble Type	Sets the preamble type	Long, Short: Available in the following conditions: System = 11b, System = 11g (Only Long can be set when System = 11g, Frame Format = ERP-DSSS, Data Rate = 1 Mbps) (Only Long can be set when System = 11g, and Frame Format = ERP-OFDM) (Only Long can be set when System = 11b, and Data Rate = 1 Mbps)
Frame Format	Sets the secondary modulation scheme of the header and payload	ERP-OFDM, DSSS-OFDM, ERP-DSSS, ERP-CCK, ERP-PBCC: Available in the following conditions: System = 11g
Spatial Mapping	Sets the spatial mapping mode	Direct Mapping, Spatial Expansion, Edit Mode: Available in the following conditions: System = 11n and PPDU Format = HT Mixed, or HT Greenfield (Direct Mapping is available only when: Number of Space Time Streams = Number of Transmit Chains) (Direct Mapping can be set only when: Number of Transmit Chains = 1)
Edit Mode	Sets spatial mapping matrix	-1.00000-j1.00000 to 1.00000+j1.00000 The setting resolution is 0.00001 for both real and imaginary parts
Spatial Mapping Matrix	Extends the stream from space time stream to transmit chains	Number of Transmit Chains 1 to 4 Number of Space Time Streams 1 to 3
GI	Sets the guard interval	Short, Long: Available in the following conditions: System = 11n and PPDU Format = HT Mixed, or HT Greenfield
Smoothing	Enables/Disables smoothing processing	On, Off: Available in the following conditions: System = 11n and PPDU Format = HT Mixed, or HT Greenfield
Not Sounding	Enables/Disables not sounding processing	On, Off: Available in the following conditions: System = 11n and PPDU Format = HT Mixed, or HT Greenfield
Number of Transmit Chains	Sets number of transmit chains	1 to 4: Available in the following conditions: System = 11n and PPDU Format = HT Mixed, or HT Greenfield A value equal to or greater than that set for Number of Space Time Streams can be set for Number of Transmit Chains
Number of Space Time Streams	Sets the number of space time streams	1 to 4: Available in the following conditions: System = 11n and PPDU Format = HT Mixed, or HT Greenfield A value equal to or greater than that set for Number of Spatial Streams can be set for Number of Space Time Streams
Number of Extension Spatial Streams	Sets number of extension spatial streams	0 to (Number of Transmit Chains-Number of Space Time Streams): Available in the following conditions: System = 11n and PPDU Format = HT Mixed, or HT Greenfield
Half Bandwidth	Sets the carrier arrangement when bandwidth = 40 MHz	Lower Mode, Upper Mode, N/A: This is available only when System = 11n and Bandwidth = 40 MHz (Only N/A can be set when in MCS32) (Only the lower 20 MHz of a 40 MHz channel is transmitted when Lower Mode is specified. N/A transmits 40 MHz channel as is) (Only the upper 20 MHz of a 40 MHz channel is transmitted when Upper Mode is specified. N/A transmits 40 MHz channel as is)

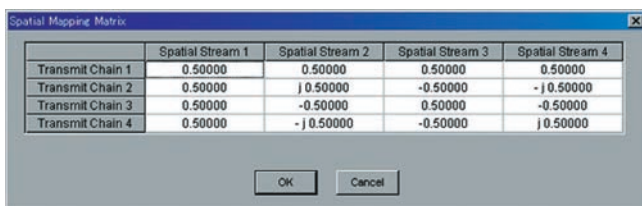

System = 11n, PPDU Format = HT Mixed or HT Greenfield,
System = 11ac,
Can be set when Spatial Mapping = Edit Mode.

Edit Mode in Spatial Mapping

Optional

MS269xA

MS2830A

PHY Parameter Setting Range (System = 11ac)

Display	Outline	Setting Range
Scramble	Enables/disables scramble processing	On, Off
MCS	Sets the MCS	0 to 9
Number of Spatial Streams	Sets the number of spatial streams	1 to 8 The setting range is 1 to 4 when the user mode is Multi User
Modulation	Displays the modulation scheme of PSDU	BPSK, QPSK, 16QAM, 64QAM, 256QAM The value depends on MCS
Code Rate	Displays the code rate	1/2, 2/3, 3/4, 5/6 The value depends on MCS
Coding	Sets of the coding is On or Off	Fixed to On for System = 11ac
Coding Mode	Sets the coding mode	Fixed to BCC for System = 11ac
BCC Interleaver	Enables/disables BCC Interleaver	Fixed to On for System = 11ac
LDPC Tone Mapper	Enables/disables LDPC Tone Mapper	On, Off Void for System = 11ac
Number of Space Time Streams	Sets the number of space time stream	The same value as Number of Spatial Stream, Number of Spatial Stream × 2 Number of Spatial Streams × 2 is settable only when Number of Spatial Streams × 2 ≤ Number of Transmit Chains. When the user mode is set to Multi User, Number of Spatial Streams × 2 is not settable unless Number of Spatial Streams ≤ 2 for each User#
Group ID	Sets the group ID	0x00, 0x3F (User Mode = Single User) 0x01 to 0x3E (User Mode = Multi User)
Partial AID	Sets Partial AID	0x000 to 0x1FF Void when User Mode = Multi User
TXOP PS NOT ALLOWED	Sets TXOP PS NOT ALLOWED	0, 1

MAC Parameter Setting Range (System = other than 11ac)

Display	Outline	Setting Range
Data Length	Sets the data wavelength	System = 11a, 11b, 11g, 11j, 11p, or System = 11n and PPDU format = Non-HT: 1 to (4095-Diff) System = 11n, and PPDU Format = HT Mixed, or HT Greenfield: 1 to (65535-Diff) Diff refers to a value (octets) obtained by subtracting the value of Total Length (MAC header + FCS) from the total number of MAC parameters that are set to Off in the MAC Frame Format setting window. Total Length = 40 [octet (s)]
MPDU Length	Displays the MPDU length	System = 11a, 11b, 11g, 11j, 11p, or System = 11n and PPDU format = Non-HT: (Diff+1) to 4095 System = 11n, and PPDU Format = HT Mixed, or HT Greenfield: (Diff+1) to 65535 System = 11n, and A-MPDU = ON: (Diff+1) to 4095
MAC Frame Type	Sets the MAC Frame type	MAC information can be set (See diagram below)
MAC Data Type	Displays the type of data assigned to the MAC frame body	PN9fix, PN15fix, 16bit repeat, User File
Data Type Repeat Data	Sets 16-bit data to be assigned to the MAC frame body	0x0000 to 0xFFFF (This parameter is displayed only when 16 bit repeat is selected for MAC Data Type)
Data Type User File	Sets a user file to be assigned to the MAC frame body	Any file can be selected (This parameter is displayed only when User File is selected for MAC Data Type)
Frame Control	Sets the frame control	0x0000 to 0xFFFF
Duration/ID	Sets the Duration/ID	0x0000 to 0xFFFF
Address1/2/3/4	Sets the address1/2/3/4	0x0000 0000 0000 to 0xFFFF FFFF FFFF
Sequence Control	Sets the sequence control	0x0000 to 0xFFFF
QoS Control	Sets the QoS control	0x0000 to 0xFFFF
HT Control	Sets the HT control	0x0000 0000 to 0xFFFF FFFF
MAC FCS	Enables/Disables the MAC FCS	On, Off
Increment Sequence Number	Enables/Disables the Increment sequence number	On, Off If set to On, the count-up operation starts from the upper 12 bits of the value specified for Sequence Control, incrementally at each interval specified by Sequence Number Increment Period
Sequence Number Increment Period	Sets the interval to count up the sequence number	1 to 15: This is available when Increment Sequence Number is set to On
Increment Fragment Number	Enables/Disables the Increment fragment number	On, Off If set to On, the count-up operation starts from the lower 4 bits of the value specified for Sequence Control, incrementally for each packet at each interval specified by Sequence Number Increment Period

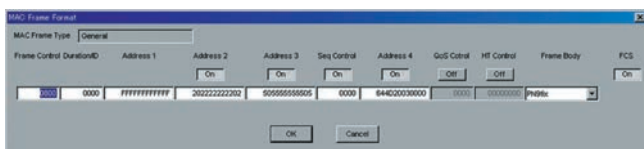

MAC Frame Format Setting Screen

Opened by double-clicking MAC Frame Type [General] on MAC parameter setting screen

MAC Parameter Setting Range (System = 11ac)

Display	Outline	Setting Range
A-MPDU	Enables/disables A-MPDU for each User#	On, Off If A-MPDU is set to Off in one A-MPDU#, all MPDU/A-MPDU# under other User#s are all set to Off
Data Length	Set the data length	1 to (65535 - Diff) (A-MPDU = Off) 1 to (16384 - Diff) (A-MPDU = On) Diff = Total Length(Mac Header + FCS) - (Sum of MAC parameters [octet(s)] that are Off on MAC Frame Format setting window.) Total Length = 40 [octet(s)]
MPDU Length	Displays the MPDU length	(Diff + 1) to 65535 (A-MPDU = Off) (Diff + 1) to 16384 (A-MPDU = On) When Oversampling Ratio = 8, Bandwidth = 20 MHz, MCS = 0, Number of Spatial Streams = 1, A-MPDU = Off: (Diff + 1) to 42500
Total A-MPDU Length	Displays the total A-MPDU Length directly under each User#	1 to 262140 Void when A-MPDU is Off
MAC Frame Type	Sets the type of MAC Frame	Sets the MAC information
MAC Data Type	Sets the data type to be inserted into Mac Frame body	PN9fix, PN15fix, 16bit repeat, User File
Data Type Repeat Data	Sets the 16 bit data to be inserted into Mac Frame body	0x0000 to 0xFFFF (This parameter is displayed only when 16 bit repeat is selected for MAC Data Type)
Data Type User File	Sets the user file to be inserted into Mac Frame body	Any file can be selected (This parameter is displayed only when User File is selected for MAC Data Type)
Frame Control	Sets the frame control	0x0000 to 0xFFFF
Duration/ID	Sets Duration/ID	0x0000 to 0xFFFF
Address1/2/3/4	Sets MAC Address1/2/3/4	0x0000 0000 0000 to 0xFFFF FFFF FFFF
Sequence Control	Sets the Sequence Control	0x0000 to 0xFFFF
QoS Control	Sets the QoS Control	0x0000 to 0xFFFF
HT Control	Sets the HT Control	0x0000 0000 to 0xFFFF FFFF
MAC FCS	Enables/disables the MAC FCS	On, Off
Increment Sequence Number	Enables/disables the Increment of Sequence Number	On, Off If the Increment of Sequence Number sets to On, the count-up operation starts from the upper 12 bits of the value specified for Sequence Control, incrementally at each interval specified by Sequence Number Increment Period
Sequence Number Increment Period	Sets the interval to count up the sequence number	1 to 15 This is available when Increment Sequence Number or Increment Fragment Number is set to On
Increment Fragment Number	Enables/disables the Increment Fragment Number	On, Off If Increment Fragment Number sets to On, the count-up operation starts from the lower 4 bits of the value specified for Sequence Control, incrementally for each packet at each interval specified by Sequence Number Increment Period

TD-SCDMA IQproducer MX269912A is PC application software with a GUI for changing parameters and generating waveform patterns in compliance with TD-SCDMA specifications standardized by 3GPP TS 25.221, TS 25.222, TS 25.223, TS 25.105, TS 25.142 (supports TRx tests excluding performance tests).

Sub-frame Structure Screen

Displays RU (Resource Unit) for each channel in different colors. Arranges in cells for 7 slots (for 1 Sub-frame) in RU units.

Horizontal axis: Time Slot, 7RU
Vertical axis: Channel Code, 16RU

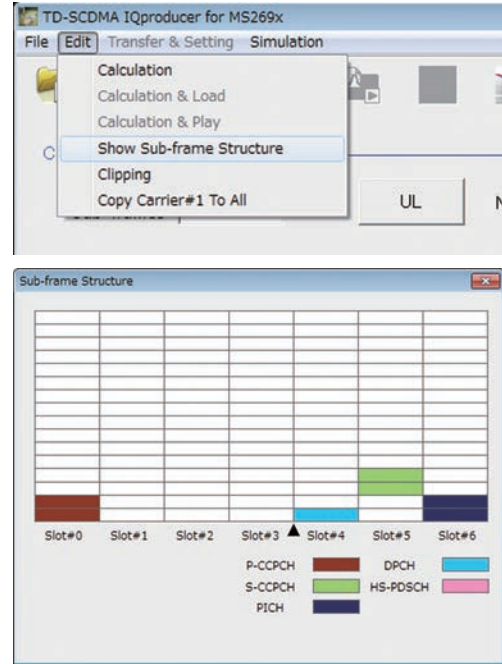

TD-SCDMA IQproducer Setting Screen

Supports both uplink and downlink and settings for up to 6 carriers.

Midamble Config

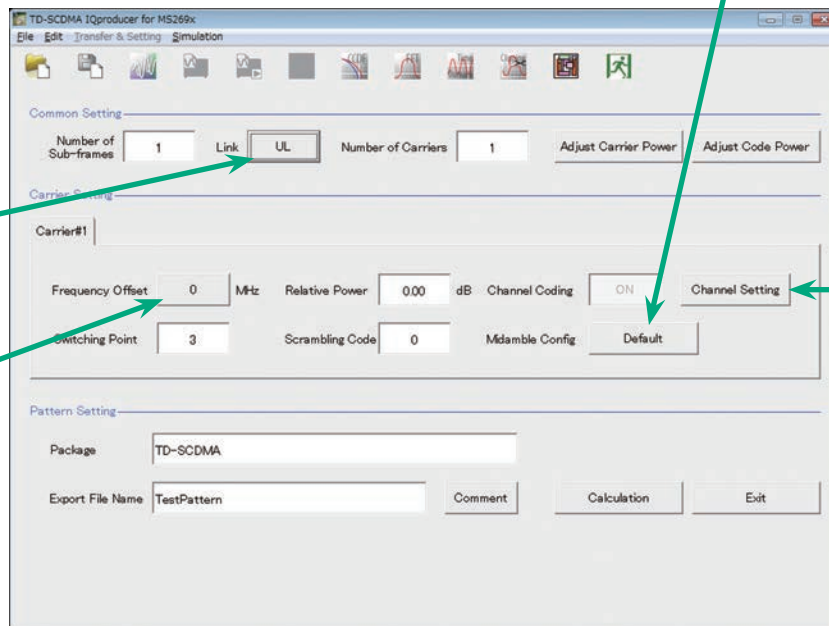

Channel Setting (See next page.)

TD-SCDMA IQproducer Setting Screen

Channel Setting Screen

Sets channel parameters for carriers with different channel for uplink and downlink.

For Uplink

- UpPCH
- DPCH

For Downlink

- P-CCPCH
- S-CCPCH
- DwPCH
- PICH
- DPCH
- HS-PDSCH

Uplink/UpPCH

Uplink/DPCH

Downlink/P-CCPCH

Downlink/S-CCPCH

Downlink/DwPCH

Downlink/PICH

Downlink/DPCH

Downlink/HS-PDSCH

Common Parameter Setting Range

Display	Outline	Setting Range
Number of sub-frames	Sets the number of sub-frames	<Table 1>
Link	Sets Downlink and Uplink signals	UL, DL
Number of Carriers	Sets number of carriers	1 to 6
Adjust Carrier Power	Adjusts Relative Power of each Carrier so that the maximum value of Relative Power is 0.00 dB	
Adjust Code Power	Adjusts each Carrier so that the maximum value of the channel Power is 0.00 dB	

Table 1

MS269x	Memory	256 Msamples	—
	1	10485	—
	2	5242	—
	3 to 6	2621	—
MS2830	Memory Option	Without Option 27 (Memory 256 Msamples)	With Option 27 (Memory 256 Msamples)
	1	2621	10485
	2	1310	5242
	3 to 6	655	2621

Carrier Parameter Setting Range

Display	Outline	Setting Range
Frequency Offset	Sets carrier frequency offset	-4.0, -3.2, -2.4, -1.6, -0.8, 0, +0.8, +1.6, +2.4, +3.2, +4.0 MHz The frequency offset range of selectable carrier varies according to the setting of Number of Carriers.
Relative Power	Sets the level ratio of selected carrier	0.00 to -40.00 dB, Resolution 0.01 dB
Channel Coding	Enables/disables channel coding	Link = DL: Off Link = UL: On You cannot change the parameter of this function with this version.
Switching Point	Sets a Switching Point position (switching timing between DL and UL)	1 to 6 (This is set after Time Slot with the same value.) When Link is DL, a value beyond Time Slot (later in time) where Channel is already allocated cannot be set to Switching Point. When Link is UL, a value smaller than Time Slot (earlier in time) where Channel is already allocated cannot be set to Switching Point.
Scrambling Code	Sets the scrambling code	0 to 127
Midamble Config	Displays the Midamble Config.	Default, Common, UE Specification

Channel Parameter Setting Range

Display	Outline	Setting Range
When Link is DL		
P-CCPCH		
State	Turns On/Off the channel	On, Off
Power	Sets channel power	0.00 to -40.00 dB, Resolution 0.01 dB
Data Type	Sets the data type to be mapped to channel	PN9, PN15, All 0, All 1, User File
Midamble Config	Displays the Midamble Config.	The Midamble Config value set in Carrier Setting will be displayed.
Midamble K	Displays the Midamble K value	2, 4, 6, 8, 10, 12, 14, 16
UE spec shift	Sets the UE spec shift value	1 to Midamble K
SF	Displays the spreading factor	Display only
S-CCPCH		
State	Turns On/Off the channel	On, Off
Power	Sets channel power	0.00 to -40.00 dB, Resolution 0.01 dB
Time Slot	Sets the position of Time Slot to be allocated	0, 2 to 6
Data Type	Sets the data type to be mapped to channel	PN9, PN15, All 0, All 1, User File
Channel Code	Sets the Channelization Code	1 to 15
Midamble Config	Displays the Midamble Config.	The Midamble Config value set in Carrier Setting will be displayed.
Midamble K	Sets the Midamble K value	2, 4, 6, 8, 10, 12, 14, 16
UE spec shift	Sets the UE spec shift value	1 to Midamble K
SF	Displays the spreading factor	Display only
DwPCH		
State	Turns On/Off the channel	On, Off
Power	Sets channel power	0.00 to -40.00 dB, Resolution 0.01 dB
Sync-DL code	Sets the Sync-DL code	It is auto-calculated from the Scrambling Code of Carrier Setting.

TD-SCDMA IQproducer MX269912A

Optional

MS269xA

MS2830A

Display	Outline	Setting Range
PICH		
State	Turns On/Off the channel	On, Off
Power	Sets channel power	0.00 to -40.00 dB, Resolution 0.01 dB
Time Slot	Sets the position of Time Slot to be allocated	0, 2 to 6
Channel Code	Sets the Channelisation Code	1 to 15
Data Type	Sets the data type to be mapped to channel	PN9, PN15, All 0, All 1, User File
Midamble Config	Displays the Midamble Config.	The Midamble Config value set in Carrier Setting will be displayed.
Midamble K	Sets the Midamble K value	2, 4, 6, 8, 10, 12, 14, 16
UE spec shift	Sets the UE spec shift value	1 to Midamble K
SF	Displays the spreading factor	Display only
DPCH		
Number of RMC	Sets the number of RMC	1 to 8
RMC	Sets the RMC number, which edits detailed parameter	1 to Number of RMC
State	Turns On/Off the channel	On, Off
Power	Sets channel power	0.00 to -40.00 dB, Resolution 0.01 dB
Time Slot	Sets the position of Time Slot to be allocated	0, 2 to 6
Channel Code	Sets the Channelisation Code	1 to SF
DTCH Data Type	Sets the data type to be mapped to channel	PN9, PN15, All 0, All 1, User File
SF	Sets the spreading factor	1, 16
Midamble Config	Displays the Midamble Config.	The Midamble Config value set in Carrier Setting will be displayed.
Midamble K	Sets the Midamble K value	2, 4, 6, 8, 10, 12, 14, 16
UE spec shift	Sets the UE spec shift value	1 to Midamble K
Number of DPCH per TS	Sets the number of DPCH per each time slot	1 to (SF - Channel Code + 1)
HS-PDSCH		
State	Turns On/Off the channel	On, Off
Power	Sets channel power	0.00 to -40.00 dB, Resolution 0.01 dB
Time Slot	Sets the position of Time Slot to be allocated	0, 2 to 6
Channel Code	Sets the Channelisation Code	1 to SF
Data Type	Sets the data type to be mapped to channel	PN9, PN15, All 0, All 1, User File
Midamble Config	Displays the Midamble Config.	The Midamble Config value set in Carrier Setting will be displayed.
Midamble K	Sets the Midamble K value	2, 4, 6, 8, 10, 12, 14, 16
UE spec shift	Sets the UE spec shift value	1 to Midamble K
Number of HS-PDSCH per TS	Sets the number of HS-PDSCH per each time slot	1 to SF
Number of TS	Sets the number of time slots that HS-PDSCH uses	1 to (6 - Switching Point)
SF	Sets the spreading factor	1, 16
Modulation	This sets the modulation method of HS-DPCH	QPSK, 16QAM, 64QAM
When Link is UL		
UpPCH		
State	Turns On/Off the channel	On, Off
Power	Sets channel power	0.00 to -40.00 dB, Resolution 0.01 dB
Sync-UL code	Displays the Sync-UL code	floor (Scrambling Code / 4) × 8 to floor (Scrambling Code / 4) × 8 + 7 Where floor(x) is the function for finding the largest integer that does not exceed x.
DPCH		
Number of RMC	Sets the number of RMC	1 to 8
RMC	Sets the RMC number, which edits detailed parameter	1 to Number of RMC
State	Turns On/Off the channel	On, Off
Power	Sets channel power	0.00 to -40.00 dB, Resolution 0.01 dB
RMC Type	Sets the RMC type	12.2 kbps, 64 kbps, 144 kbps, 384 kbps 144 kps is available when the difference of Switching Point - (Time Slot - 1) is 2 or more. 384 kps is available when the difference of Switching Point - (Time Slot - 1) is 4 or more.
Time Slot	Sets the position of Time Slot to be allocated	1 to 6
Channel Code	Sets the Channelization Code	1 to SF
DTCH Data Type	Sets the data type to be mapped to DTCH	PN9, PN15, All 0, All 1, User File
DTCH Rate Matching Attribute	Sets the Rate Matching attribute of DTCH	Display only

Display	Outline	Setting Range
DCCH Data Type	Sets the data type to be mapped to DCCH	PN9, PN15, All 0, All 1, User File
DCCH Rate Matching Attribute	Displays the Rate Matching attribute of DCCH	Display only
SF	Displays the spreading factor	Display only
TFCI	Sets the TFCI (Transport Format Combination Indicator)	0 to 31
TPC	Sets the TPC (Transmitter Power Control)	Repeat 1010, Repeat 0101, All 0, All 1, User File
SS	Sets the synchronization shift parameter	Repeat 1010, Repeat 0101, All 0, All 1, User File
Midamble Config.	Displays the Midamble Config.	The Midamble Config. value set in Carrier Setting will be displayed.
Midamble K	Sets the Midamble K value	2, 4, 6, 8, 10, 12, 14, 16
UE spec shift	Sets the UE spec shift value	1 to Midamble K
Block Size	Sets the block size of information data	Display only

1xEV-DO Reverse Receiver Test Waveform Pattern MX269970A

Optional

MS269xA

MS2830A

Installing the 1xEV-DO Reverse Receiver Test Waveform Patterns in either the MS269xA or MS2830A signal analyzers with the MS269xA-020 or MS2830A-020/021 Vector Signal Generator option installed supports selection and output of the 1xEV-DO Revision A Reverse Link Waveform Patterns listed in the following table. This function can be used for receiver tests of 1xEV-DO access networks (base stations).

Waveform patterns and reverse traffic channel parameters

Recorded waveform pattern count: 12

Waveform Pattern Name	Modulation Method	Payload Size (bits)	Data Channel Gain (dB)
Rev_A_RVS_B4_128	B4	128	0.75
Rev_A_RVS_B4_256	B4	256	3.75
Rev_A_RVS_B4_512	B4	512	7.00
Rev_A_RVS_B4_768	B4	768	8.75
Rev_A_RVS_B4_1024	B4	1024	10.00
Rev_A_RVS_Q4_1536	Q4	1536	11.50
Rev_A_RVS_Q4_2048	Q4	2048	13.00
Rev_A_RVS_Q2_3072	Q2	3072	14.25
Rev_A_RVS_Q2_4096	Q2	4096	15.50
Rev_A_RVS_Q4Q2_6144	Q4Q2	6144	17.00
Rev_A_RVS_Q4Q2_8192	Q4Q2	8192	18.50
Rev_A_RVS_E4E2_12288	E4E2	12288	21.25

B4: BPSK 4-ary Walsh cover

Q4: QPSK 4-ary Walsh cover

Q2: QPSK 2-ary Walsh cover

E4: 8-PSK modulated with 4-ary Walsh cover

E2: 8-PSK modulated with 4-ary Walsh cover

Q4Q2: Connects Q4 and Q2

E4E2: Connects E4 and E2

Common Waveform Pattern Specifications

Parameters	Value
Basic Specification	CDMA2000 1xEV-DO Revision A Reverse Link (conforming to 3GPPS2)
Waveform Length	3 frames (80 ms)
Baseband Filter	IS-95 specification
Payload Data	PN9fix (The PN sequence is discontinuous at the waveform pattern connection.)
DRC Channel Gain	3.0 dB
ACK Channel Gain	0.0 dB
DSC Channel Gain	-9.0 dB
RRI Channel Gain	-6.0 dB
Auxiliary Pilot Channel Gain	12.0 dB below Data Channel Gain
Long Code Mask MI	0x3FF00000000
Long Code Mask MQ	0x3FE00000001
DRC Data	All 0x1
DRC Cover	All 0x1
ACK Data	All ACK
DSC Data	All 0x1
External Trigger Function	Start trigger function (The frame trigger function cannot be used with the MX269970A.)

Ordering Information

Please specify the model/order number, name and quantity when ordering.
The names listed in the chart below are Order Names. The actual name of the item may differ from the Order Name.

Model/Order No.	Name
- Main frame -	
MS2690A	Signal Analyzer (50 Hz to 6.0 GHz)
MS2691A	Signal Analyzer (50 Hz to 13.5 GHz)
MS2692A	Signal Analyzer (50 Hz to 26.5 GHz)
MS2840A-040	3.6 GHz Signal Analyzer (9 kHz to 3.6 GHz)
MS2840A-041	6 GHz Signal Analyzer (9 kHz to 6.0 GHz)
MS2830A-040	3.6 GHz Signal Analyzer (9 kHz to 3.6 GHz)
MS2830A-041	6 GHz Signal Analyzer (9 kHz to 6.0 GHz)
MS2830A-043	13.5 GHz Signal Analyzer (9 kHz to 13.5 GHz)
- Vector Signal Generator option -	
MS2690A-020	Vector Signal Generator (125 MHz to 6 GHz)
MS2691A-020	Vector Signal Generator (125 MHz to 6 GHz)
MS2692A-020	Vector Signal Generator (125 MHz to 6 GHz)
MS2840A-020	3.6 GHz Vector Signal Generator (250 kHz to 3 GHz)
MS2840A-021	6 GHz Vector Signal Generator (250 kHz to 6 GHz)
MS2840A-022	Low Power Extension for Vector Signal Generator
MS2840A-027	ARB Memory Upgrade 256 MSa for Vector Signal Generator
MS2840A-028	AWGN
MS2830A-020	3.6 GHz Vector Signal Generator (250 kHz to 3 GHz)
MS2830A-021	6 GHz Vector Signal Generator (250 kHz to 6 GHz)
MS2830A-022	Low Power Extension for Vector Signal Generator
MS2830A-027	ARB Memory Upgrade 256 MSa for Vector Signal Generator
MS2830A-028	AWGN

Model/Order No.	Name
- Software options -	
	CD-ROM with license and operation manuals
MX269901A	HSDPA/HSUPA IQproducer
MX269902A	TDMA IQproducer
MX269904A	Multi-Carrier IQproducer
MX269905A	Mobile WiMAX IQproducer
MX269908A	LTE IQproducer
MX269908A-001	LTE-Advanced FDD Option (Requires MX269908A)
MX269910A	LTE TDD IQproducer
MX269910A-001	LTE-Advanced TDD Option (Requires MX269910A)
MX269911A	WLAN IQproducer
MX269911A-001	802.11ac (80 MHz) Option (Requires MX269911A)
MX269912A	TD-SCDMA IQproducer
MX269970A	1xEV-DO Reverse Receiver Test Waveform Pattern (CD)
- Application parts -	
Following operation manuals provided as hard copy	
W2915AE	MX269901A Operation Manual
W2916AE	MX269902A Operation Manual
W2917AE	MX269904A Operation Manual
W2918AE	MX269905A Operation Manual
W3023AE	MX269908A Operation Manual
W3221AE	MX269910A Operation Manual
W3488AE	MX269911A Operation Manual
W3582AE	MX269912A Operation Manual
W3675AE	MX269970A Operation Manual

Note:

• United States

Anritsu Company

1155 East Collins Blvd., Suite 100, Richardson,
TX 75081, U.S.A.

Toll Free: 1-800-267-4878

Phone: +1-972-644-1777

Fax: +1-972-671-1877

• Canada

Anritsu Electronics Ltd.

700 Silver Seven Road, Suite 120, Kanata,
Ontario K2V 1C3, Canada

Phone: +1-613-591-2003

Fax: +1-613-591-1006

• Brazil

Anritsu Eletronica Ltda.

Praça Amadeu Amaral, 27 - 1 Andar

01327-010 - Bela Vista - Sao Paulo - SP

Brazil

Phone: +55-11-3283-2511

Fax: +55-11-3288-6940

• Mexico

Anritsu Company, S.A. de C.V.

Av. Ejército Nacional No. 579 Piso 9, Col. Granada

11520 México, D.F., México

Phone: +52-55-1101-2370

Fax: +52-55-5254-3147

• United Kingdom

Anritsu EMEA Ltd.

200 Capability Green, Luton, Bedfordshire, LU1 3LU, U.K.

Phone: +44-1582-433200

Fax: +44-1582-731303

• France

Anritsu S.A.

12 avenue du Québec, Bâtiment Iris 1- Silic 612,

91140 VILLEBON SUR YVETTE, France

Phone: +33-1-60-92-15-50

Fax: +33-1-64-46-10-65

• Germany

Anritsu GmbH

Nemetschek Haus, Konrad-Zuse-Platz 1

81829 München, Germany

Phone: +49-89-442308-0

Fax: +49-89-442308-55

• Italy

Anritsu S.r.l.

Via Elio Vittorini 129, 00144 Roma, Italy

Phone: +39-6-509-9711

Fax: +39-6-502-2425

• Sweden

Anritsu AB

Kistagången 20B, 164 40 KISTA, Sweden

Phone: +46-8-534-707-00

Fax: +46-8-534-707-30

• Finland

Anritsu AB

Teknobulevardi 3-5, FI-01530 VANTAA, Finland

Phone: +358-20-741-8100

Fax: +358-20-741-8111

• Denmark

Anritsu A/S

Kay Fiskers Plads 9, 2300 Copenhagen S, Denmark

Phone: +45-7211-2200

Fax: +45-7211-2210

• Russia

Anritsu EMEA Ltd.

Representation Office in Russia

Tverskaya str. 16/2, bld. 1, 7th floor.

Moscow, 125009, Russia

Phone: +7-495-363-1694

Fax: +7-495-935-8962

• Spain

Anritsu EMEA Ltd.

Representation Office in Spain

Edificio Cuzco IV, Po. de la Castellana, 141, Pta. 8

28046, Madrid, Spain

Phone: +34-915-726-761

Fax: +34-915-726-621

• United Arab Emirates

Anritsu EMEA Ltd.

Dubai Liaison Office

902, Aurora Tower,

P O Box: 500311 - Dubai Internet City

Dubai, United Arab Emirates

Phone: +971-4-3758479

Fax: +971-4-4249036

• India

Anritsu India Private Limited

2nd & 3rd Floor, #837/1, Binnamangla 1st Stage,

Indiranagar, 100ft Road, Bangalore - 560038, India

Phone: +91-80-4058-1300

Fax: +91-80-4058-1301

• Singapore

Anritsu Pte. Ltd.

11 Chang Charn Road, #04-01, Shriro House

Singapore 159640

Phone: +65-6282-2400

Fax: +65-6282-2533

• P.R. China (Shanghai)

Anritsu (China) Co., Ltd.

Room 2701-2705, Tower A,

New Caohejing International Business Center

No. 391 Gui Ping Road Shanghai, 200233, P.R. China

Phone: +86-21-6237-0898

Fax: +86-21-6237-0899

• P.R. China (Hong Kong)

Anritsu Company Ltd.

Unit 1006-7, 10/F., Greenfield Tower, Concordia Plaza,

No. 1 Science Museum Road, Tsim Sha Tsui East,

Kowloon, Hong Kong, P.R. China

Phone: +852-2301-4980

Fax: +852-2301-3545

• Japan

Anritsu Corporation

8-5, Tamura-cho, Atsugi-shi, Kanagawa, 243-0016 Japan

Phone: +81-46-296-6509

Fax: +81-46-225-8359

• Korea

Anritsu Corporation, Ltd.

5FL, 235 Pangyoyeok-ro, Bundang-gu, Seongnam-si,

Gyeonggi-do, 13494 Korea

Phone: +82-31-696-7750

Fax: +82-31-696-7751

• Australia

Anritsu Pty. Ltd.

Unit 20, 21-35 Ricketts Road,

Mount Waverley, Victoria 3149, Australia

Phone: +61-3-9558-8177

Fax: +61-3-9558-8255

• Taiwan

Anritsu Company Inc.

7F, No. 316, Sec. 1, NeiHu Rd., Taipei 114, Taiwan

Phone: +886-2-8751-1816

Fax: +886-2-8751-1817